

PARTS CATALOGUE

- YZ250FP** (5SG1) U.S.A.
YZ250F (5SG2) EUROPE
YZ250F (5SG3) JAPAN
YZ250FP (5SG4) OCEANIA,CANADA,S.AFRICA
-

YZ250FP/YZ250F
PARTS CATALOGUE
E 2002 by Yamaha Motor Co., Ltd.
1st Edition, October 2002
All rights reserved.
Any reprinting or unauthorized use
without the written permission of
Yamaha Motor Co., Ltd.
is expressly prohibited.
Printed in Japan



A4

FOREWORD

This Parts Catalogue is related to the parts for the model(s) in the below frame. When you are ordering replacement parts, please refer to this Parts Catalogue and quote both part numbers and part names correctly.

YZ250FP(5SG1/5SG4), YZ250F(5SG2/5SG3)

1. Modifications or additions which have been made after issue of the Parts Catalogue will be announced in the Yamaha Parts News. It is advisable that you make necessary corrections to the Parts Catalogue according to the Yamaha Parts News.

2. Abbreviations

The Following abbreviations are used in this Parts Catalogue.

“UR” Use specified parts number.

“UN” Use as many as needed.

“AP” Alternate Parts

“LM” Local Made (Parts need to be ordered locally)

“F#” Frame No. (Applicable machine No.)

3. Parts, which are to be supplied in an assembly, are listed with a dot(.) in front of the part name as shown below.

EXAMPLE

CARBURETOR ASSY

.JET, PILOT

.NOZZLE, MAIN

4. Number of component for assembly

The numeral appearing to the right of each component part indicates the quantity of parts for each assembly unit.

EXAMPLE

PART NO.	DESCRIPTION	Q'TY	REMARKS
2F5-83310-60	FRONT FLASHER LIGHT ASSY	2	
115-83311-60	.BULB (6V-18W)	1	
1M1-83309-60	.REFLECTOR	1	

5. Applicable colors of graphics are represented in the “REMARKS” as shown below.

PART NO.	DESCRIPTION	Q'TY	REMARKS
2N4-24110-00-X5	.FUEL TANK COMP.	2	MXR
3J1-24240-10	.GRAPHIC, FUEL TANK	1	for MXR

6. Applicable Serial No.

Engine Serial No.

Frame Serial No.

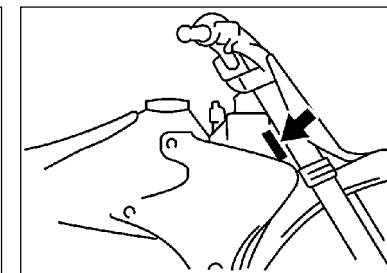
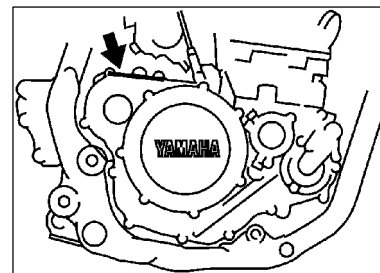

7. Note that the illustrations for reference in finding parts numbers, not to be used for assembling. When assembling, please use the applicable service manual.

8. The asterisk (*) before a reference number indicates modification items after the first edition.

MODEL LABEL

(1) A label called "Model Label" is affixed in the location as indicated in (3) below.
When using this parts catalogue, please be sure to cross-refer the "model code – production code No." in the catalogue to the "model code – production code No." indicated on the Model Label affixed onto the product concerned.

(2) "Model Label" Indication

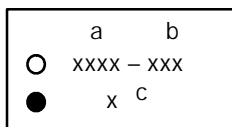

a: Model Type Code
b: Production Code No.
c: Colouring Type

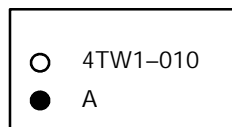

(3) Model Label Affixing Location

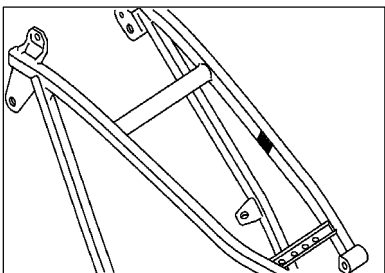

(4) Model Code – Production Code Number of Model Listed in This Parts Catalog

Model Code	Production Code No.	Country (destination)	Model Code	Production Code No.	Country (destination)
5SG1	010	USA	5SG4	030	NEWZEALAND
5SG2	010	FRANCE			SOUTH AFRICA
	020	BELGIUM			
	030	GERMANY			
	040	SPAIN			
	050		FINLAND		
			IRELAND		
	060	ENGLAND			
	070	GREECE			
	080	ITALY			
	090	PORTUGAL			
	100	SWEDEN			
5SG3	010	JAPAN			
5SG4	010	AUSTRALIA			
	020	CANADA			

(5) Colouring Information

Model Code	Colouring type code	Colour code	Colour Name	Abbreviation
5SG1 5SG2 5SG3 5SG4	A	0583	DEEP PURPLISH BLUE SOLID E	DPBSE

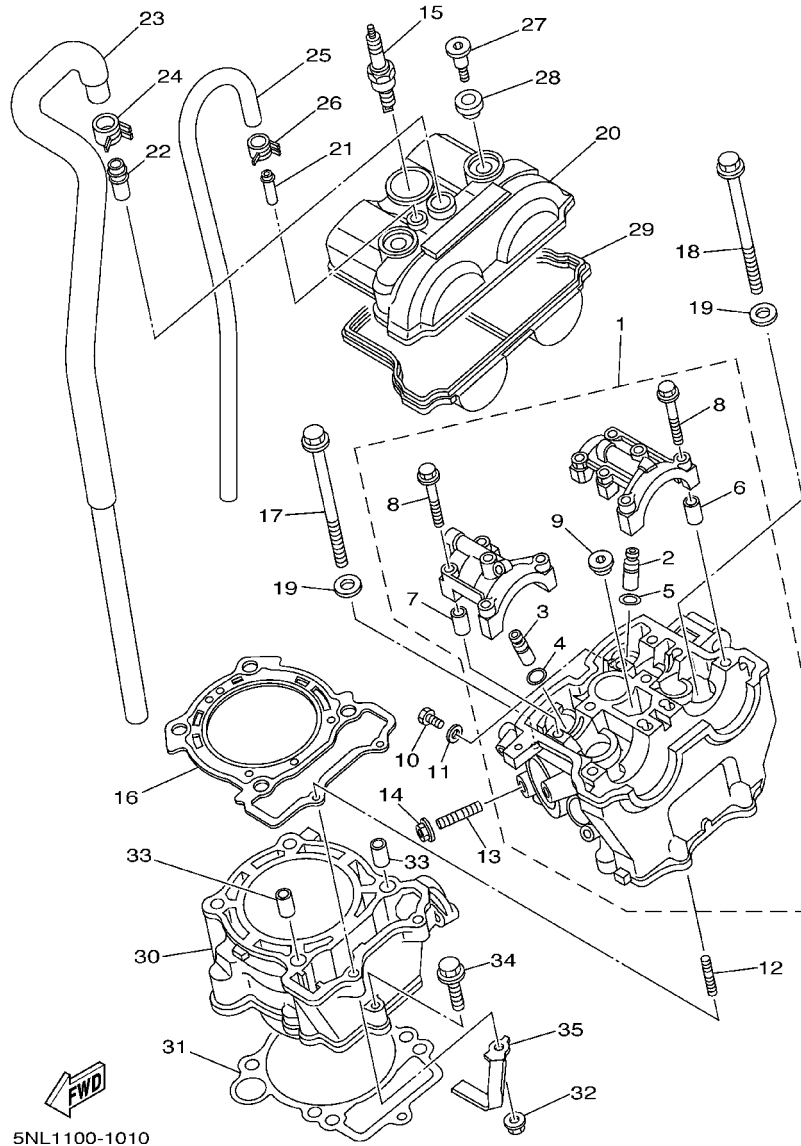

5NL1100-1010

FIG. 1 CYLINDER

REF. NO.	PART NO.	DESCRIPTION	SSG1	SSG2	SSG3	SSG4	REMARKS
1	5NL-11102-10	CYLINDER HEAD ASSY	1	1	1	1	
2	5NL-11133-10	.GUIDE, INTAKE VALVE	3	3	3	3	
3	5NL-11134-10	.GUIDE, EXHAUST VALVE	2	2	2	2	
4	93440-10153	.CIRCLIP	2	2	2	2	
5	93440-07149	.CIRCLIP	3	3	3	3	
6	91808-16023	.PIN, DOWEL	2	2	2	2	
7	91808-16023	.PIN, DOWEL	2	2	2	2	
8	90105-06027	.BOLT, FLANGE	10	10	10	10	
9	90340-12112	.PLUG, STRAIGHT SCREW	1	1	1	1	
10	95027-06012	BOLT, FLANGE	1	1	1	1	
11	90430-06014	GASKET	1	1	1	1	
12	90116-06541	BOLT, STUD	2	2	2	2	
13	95617-08620	BOLT, STUD	1	1	1	1	
14	95707-08500	NUT, FLANGE	1	1	1	1	
15	94701-00330	PLUG, SPARK (NGK-R CR8E)	1	1	1	1	STD
	94701-00329	PLUG, SPARK (U24ESR-N)	1	1	1	1	STD
	94701-00318	PLUG, SPARK (NGK R CR9E)	1	1	1	1	AP
	94701-00319	PLUG, SPARK (ND U27ESR-N)	1	1	1	1	AP
	94703-00330	PLUG, SPARK (NGK CR8E)			1	1	STD
	94703-00329	PLUG, SPARK (U24ESR-N)			1	1	STD
	94703-00318	PLUG, SPARK (NGK R CR9E)			1	1	AP
	94703-00319	PLUG, SPARK (ND U27ESR-N)			1	1	AP
16	5NL-11181-00	GASKET, CYLINDER HEAD 1	1	1	1	1	
17	90105-09555	BOLT, FLANGE	2	2	2	2	
18	90105-09002	BOLT, FLANGE	2	2	2	2	
19	90201-096J9	WASHER, PLATE	4	4	4	4	
20	5NL-11191-00	COVER, CYLINDER HEAD 1	1	1	1	1	

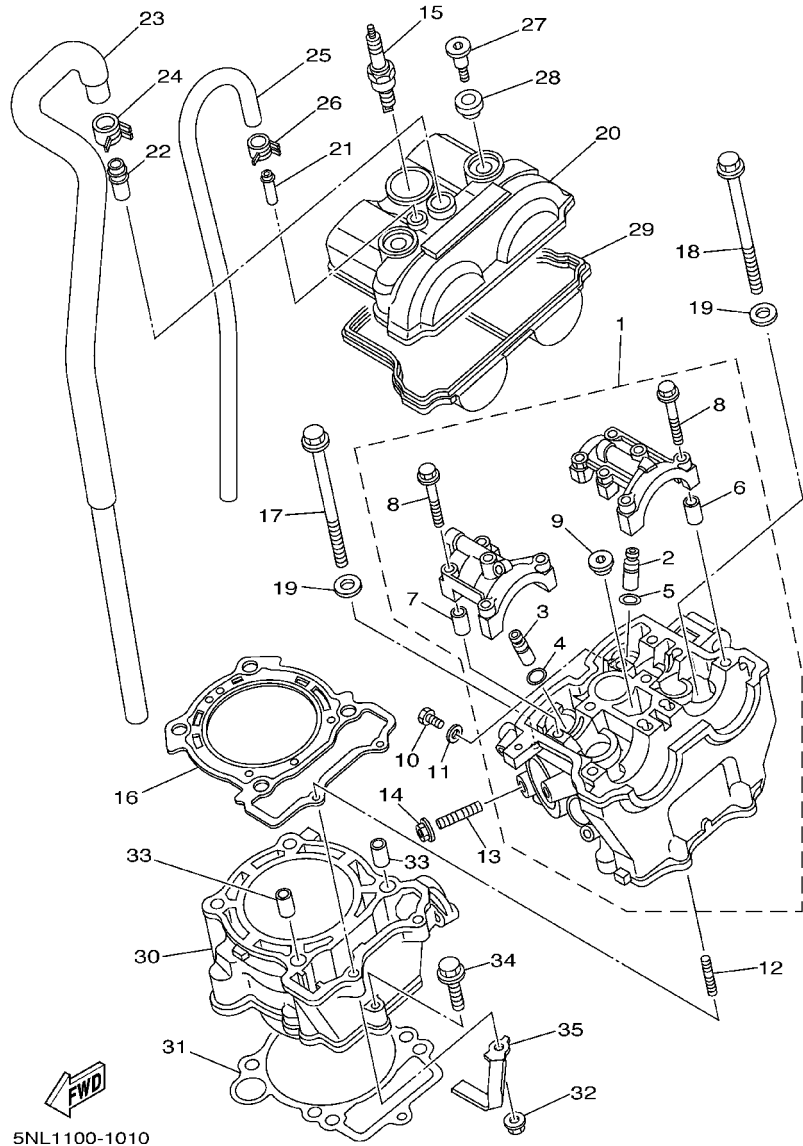
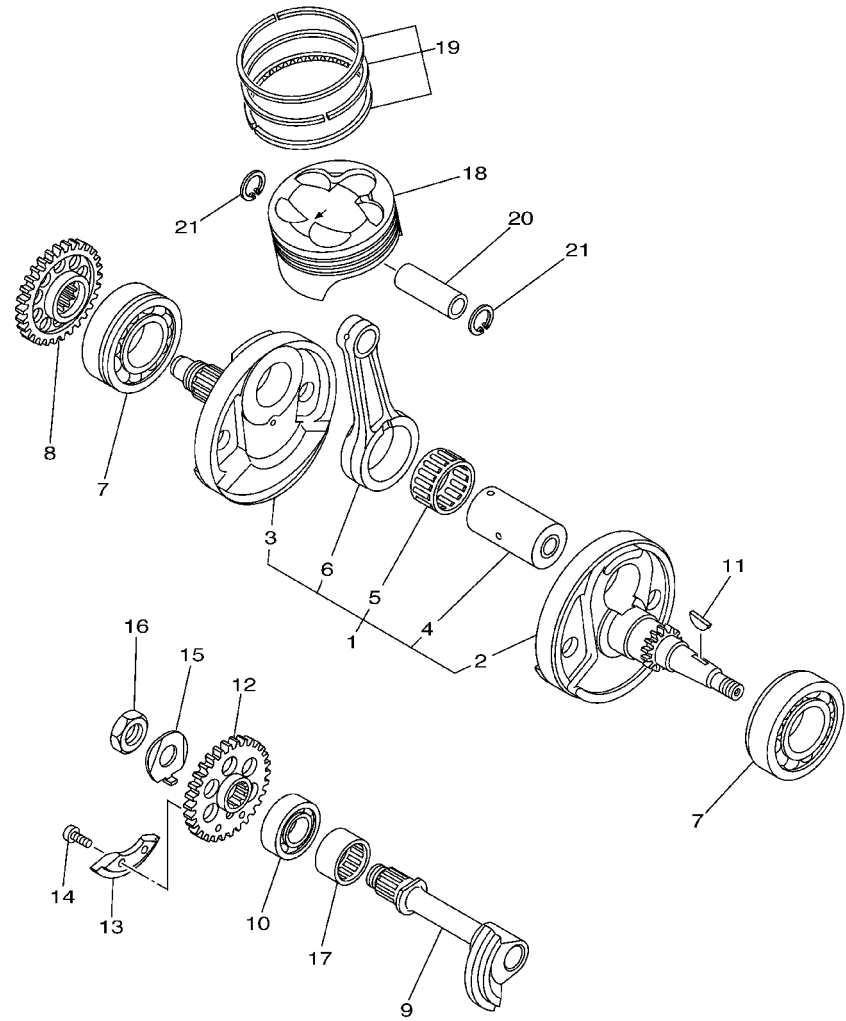

FIG. 1 CYLINDER

REF. NO.	PART NO.	DESCRIPTION	SSG1	SSG2	SSG3	SSG4	REMARKS
21	5BE-11167-00	PIPE, BREATHER 2	1	1	1	1	
22	371-11167-01	PIPE, BREATHER 2	1	1	1	1	
23	5BE-11166-00	PIPE, BREATHER 1	1	1	1	1	
24	90467-14015	CLIP	1	1	1	1	
25	90445-112K0	HOSE (L285)	1	1	1	1	
26	90467-11106	CLIP	2	2	2	2	
27	90109-066F0	BOLT	2	2	2	2	
28	4KG-1111G-00	RUBBER, MOUNT 1	2	2	2	2	
29	5NL-11193-00	GASKET, HEAD COVER 1	1	1	1	1	
30	5NL-11311-00	CYLINDER 1	1	1	1	1	
31	5NL-11351-00	GASKET, CYLINDER	1	1	1	1	
32	95704-06500	NUT, FLANGE	2	2	2	2	
33	93612-16254	PIN, DOWEL	2	2	2	2	
34	95027-06035	BOLT, FLANGE	1	1	1	1	
35	5JG-11387-00	CLAMP, HOSE 1	1	1	1	1	

FIG. 2 CRANKSHAFT. PISTON



REF. NO.	PART NO.	DESCRIPTION	SSG1	SSG2	SSG3	SSG4	REMARKS
1	5NL-11400-10	CRANKSHAFT ASSY	1	1	1	1	
2	5NL-11412-00	.CRANK 1	1	1	1	1	
3	5NL-11422-00	.CRANK 2	1	1	1	1	
4	5NL-11681-00	.PIN, CRANK 1	1	1	1	1	
5	93310-63003	.BEARING	1	1	1	1	
6	5NL-11651-10	.ROD, CONNECTING	1	1	1	1	
7	93306-20648	BEARING	2	2	2	2	
8	5NL-11536-00	GEAR, DRIVE	1	1	1	1	
9	5NL-11455-00	SHAFT 1	1	1	1	1	
10	93306-20335	BEARING	1	1	1	1	
11	90280-03001	KEY, WOODRUFF	1	1	1	1	
12	5NL-11531-00	GEAR, BALANCE WEIGHT	1	1	1	1	
13	5NL-11454-00	WEIGHT 1	1	1	1	1	
14	90149-06250	SCREW	2	2	2	2	
15	90215-14204	WASHER, LOCK	1	1	1	1	
16	90170-14171	NUT	1	1	1	1	
17	93311-32261	BEARING	1	1	1	1	
18	5NL-11631-00	PISTON (STD)	1	1	1	1	
19	5NL-11603-00	PISTON RING SET (STD)	1	1	1	1	
20	5NL-11633-00	PIN, PISTON	1	1	1	1	
21	93420-16086	CIRCLIP	2	2	2	2	



5NL1100-1020

FIG. 3 VALVE

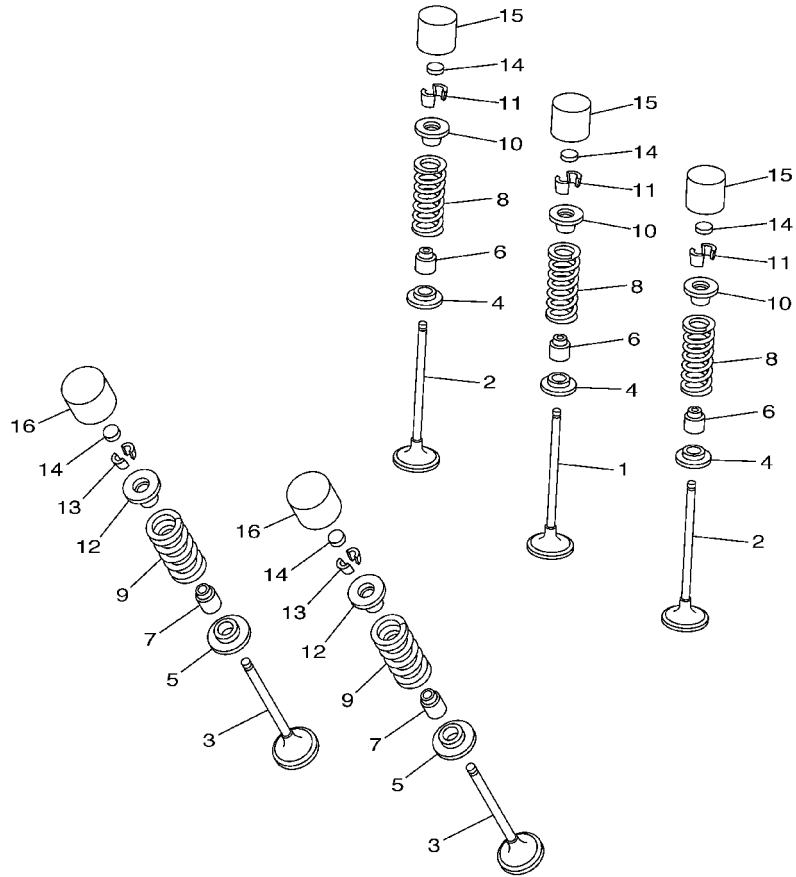

REF. NO.	PART NO.	DESCRIPTION	SSG1	SSG2	SSG3	SSG4	REMARKS
1	5NL-12111-00	VALVE, INTAKE	1	1	1	1	
2	5NL-12112-00	VALVE, INTAKE 2	2	2	2	2	
3	5NL-12121-00	VALVE, EXHAUST	2	2	2	2	
4	5NL-12116-00	SEAT, VALVE SPRING	3	3	3	3	
5	3GM-12126-00	SEAT, VALVE SPRING 2	2	2	2	2	
6	4TV-12119-00	SEAL, VALVE STEM	3	3	3	3	
7	4SV-12119-00	SEAL, VALVE STEM	2	2	2	2	
8	5NL-12113-00	SPRING, VALVE INNER	3	3	3	3	
9	5NL-12114-00	SPRING, VALVE OUTER	2	2	2	2	
10	1HX-12117-00	RETAINER, VALVE SPRING	3	3	3	3	
11	1HX-12118-00	COTTER, VALVE	6	6	6	6	
12	1WG-12117-00	RETAINER, VALVE SPRING	2	2	2	2	
13	1WG-12118-00	COTTER, VALVE	4	4	4	4	
14	1HX-12168-00	PAD, ADJUSTING 2 (1.20)	5	5	5	5	UR
	1HX-12168-20	PAD, ADJUSTING 2 (1.25)	5	5	5	5	UR
	1HX-12168-40	PAD, ADJUSTING 2 (1.30)	5	5	5	5	UR
	1HX-12168-60	PAD, ADJUSTING 2 (1.35)	5	5	5	5	UR
	1HX-12168-80	PAD, ADJUSTING 2 (1.40)	5	5	5	5	UR
	1HX-12168-A0	PAD, ADJUSTING 2 (1.45)	5	5	5	5	UR
	1HX-12168-F0	PAD, ADJUSTING 2 (1.50)	5	5	5	5	UR
	1HX-12168-H1	PAD, ADJUSTING 2 (1.55)	5	5	5	5	UR
	1HX-12168-K1	PAD, ADJUSTING 2 (1.60)	5	5	5	5	UR
	1HX-12168-M1	PAD, ADJUSTING 2 (1.65)	5	5	5	5	UR
	1HX-12168-R1	PAD, ADJUSTING 2 (1.70)	5	5	5	5	UR
	1HX-12168-U1	PAD, ADJUSTING 2 (1.75)	5	5	5	5	UR
	1HX-12168-W1	PAD, ADJUSTING 2 (1.80)	5	5	5	5	UR
	1HX-12168-Y1	PAD, ADJUSTING 2 (1.85)	5	5	5	5	UR



5NL1100-1030

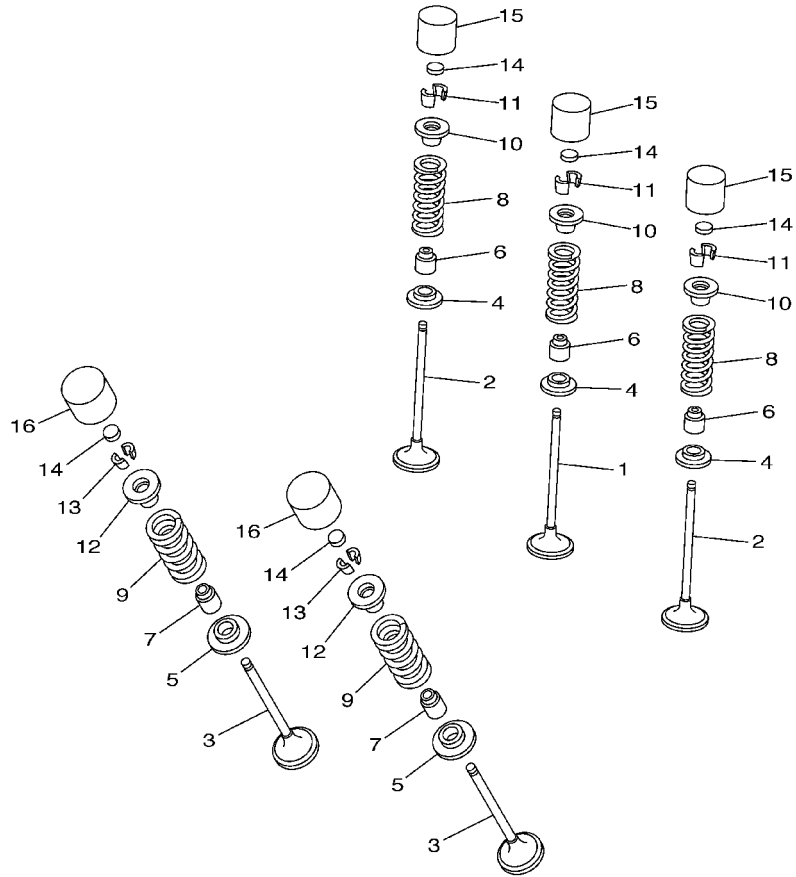

5NL1100-1030

FIG. 3 VALVE

REF. NO.	PART NO.	DESCRIPTION	SSG1	SSG2	SSG3	SSG4	REMARKS
14	1HX-12169-11	PAD, ADJUSTING 2 (1.90)	5	5	5	5	UR
	1HX-12169-31	PAD, ADJUSTING 2 (1.95)	5	5	5	5	UR
	1HX-12169-50	PAD, ADJUSTING 2 (2.00)	5	5	5	5	UR
	1HX-12169-70	PAD, ADJUSTING 2 (2.05)	5	5	5	5	UR
	1HX-12169-90	PAD, ADJUSTING 2 (2.10)	5	5	5	5	UR
	1HX-12169-E0	PAD, ADJUSTING 2 (2.15)	5	5	5	5	UR
	1HX-12169-G0	PAD, ADJUSTING 2 (2.20)	5	5	5	5	UR
	1HX-12169-J0	PAD, ADJUSTING 2 (2.25)	5	5	5	5	UR
	1HX-12169-L0	PAD, ADJUSTING 2 (2.30)	5	5	5	5	UR
	1HX-12169-N0	PAD, ADJUSTING 2 (2.35)	5	5	5	5	UR
	1HX-12169-T0	PAD, ADJUSTING 2 (2.40)	5	5	5	5	UR
15	3LN-12153-00	LIFTER, VALVE	3	3	3	3	UR BLACK
	3LN-12153-10	LIFTER, VALVE	3	3	3	3	UR YELLOW
	3LN-12153-20	LIFTER, VALVE	3	3	3	3	UR BLUE
	3LN-12153-30	LIFTER, VALVE	3	3	3	3	UR RED
16	3FV-12153-00	LIFTER, VALVE	2	2	2	2	UR BLACK
	3FV-12153-10	LIFTER, VALVE	2	2	2	2	UR YELLOW
	3FV-12153-20	LIFTER, VALVE	2	2	2	2	UR BLUE
	3FV-12153-30	LIFTER, VALVE	2	2	2	2	UR RED

FIG. 4 CAMSHAFT. CHAIN

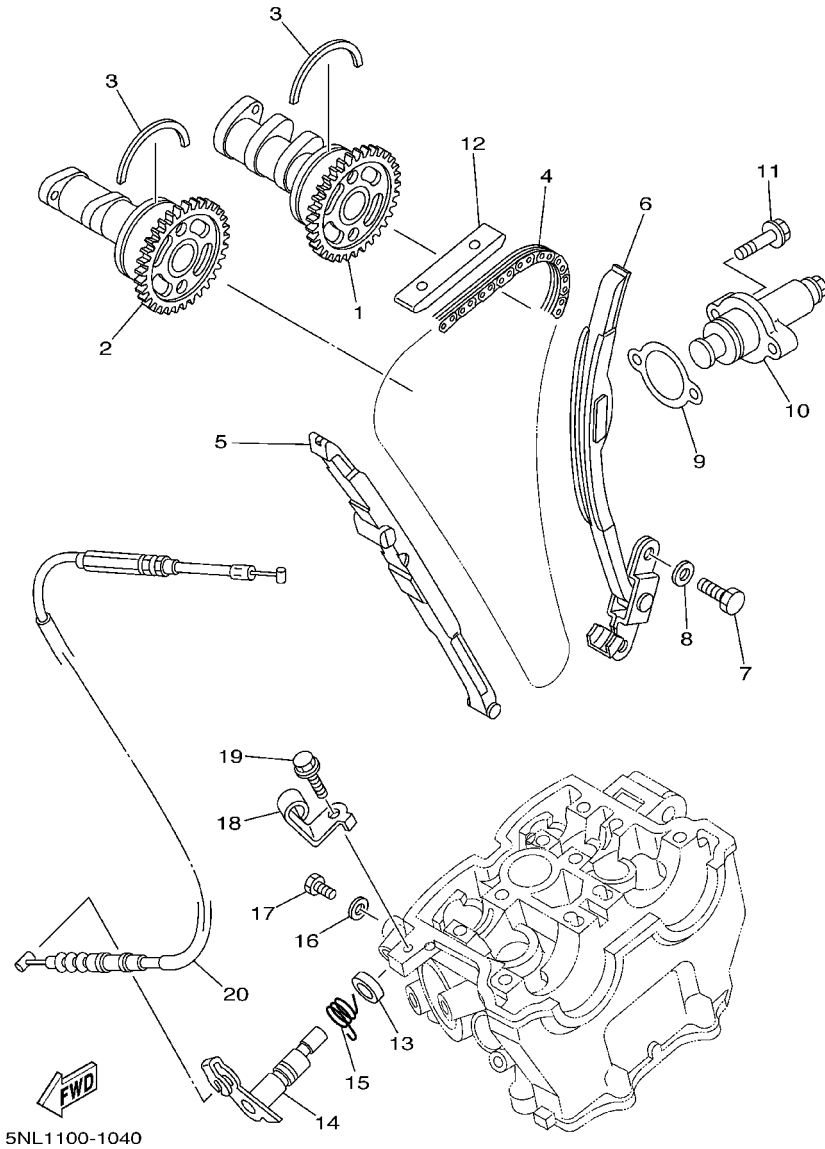

REF. NO.	PART NO.	DESCRIPTION	SSG1	SSG2	SSG3	SSG4	REMARKS
1	5NL-12170-00	CAMSHAFT ASSY 1	1	1	1	1	
2	5NL-12180-00	CAMSHAFT ASSY 2	1	1	1	1	
3	93440-41178	CIRCLIP	2	2	2	2	
4	94591-53114	CHAIN	1	1	1	1	
5	5NL-12251-00	DAMPER, CHAIN 1	1	1	1	1	
6	5NL-12252-00	DAMPER, CHAIN 2	1	1	1	1	
7	97027-06016	BOLT	2	2	2	2	
8	92907-06600	WASHER, PLATE	2	2	2	2	
9	4FM-12213-00	GASKET, TENSIONER CASE	1	1	1	1	
10	5BE-12210-00	TENSIONER ASSY, CAM CHAIN	1	1	1	1	
11	95027-06025	BOLT, FLANGE	2	2	2	2	
12	5BE-12241-00	GUIDE, STOPPER 2	1	1	1	1	
13	93102-12224	OIL SEAL	1	1	1	1	
14	5BE-12280-10	DECOMPRESSION ASSY	1	1	1	1	
15	90508-162B2	SPRING, TORSION	1	1	1	1	
16	90430-06014	GASKET	1	1	1	1	
17	90109-06418	BOLT	1	1	1	1	
18	5NL-12283-00	BRACKET, DECOMPRESSION	1	1	1	1	
19	95827-06014	BOLT, FLANGE	1	1	1	1	
20	5BE-12292-10	CABLE, DECOMPRESSION	1	1	1	1	

FIG. 5 WATER PUMP

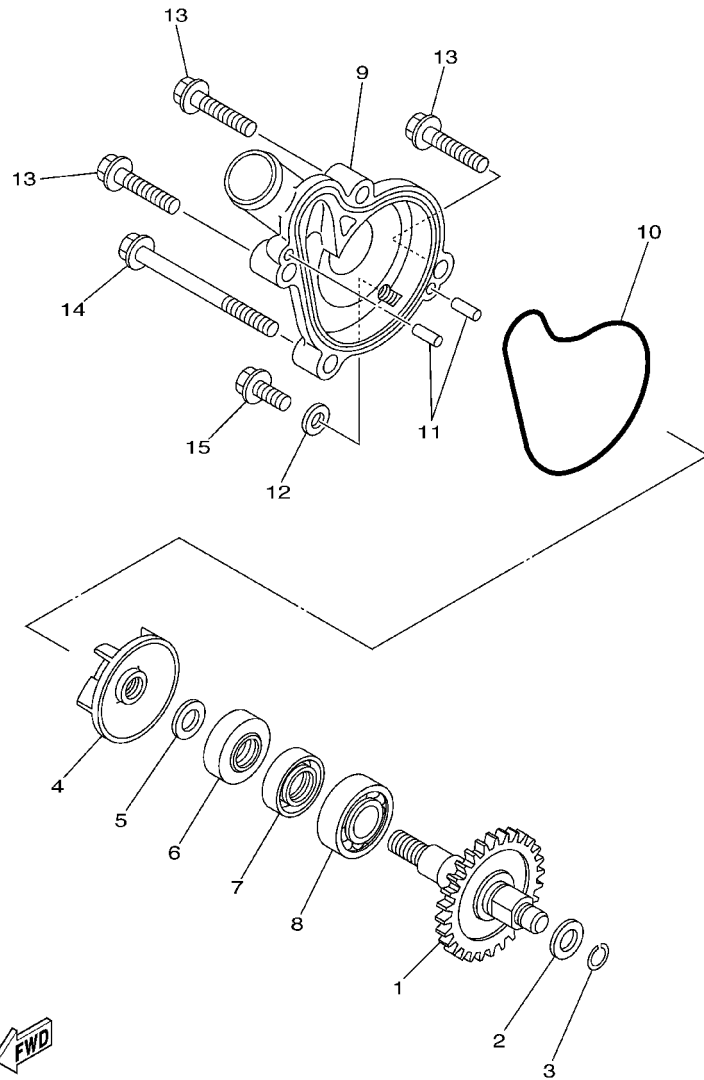

5NL1100-1050

REF. NO.	PART NO.	DESCRIPTION	5SG1	5SG2	5SG3	5SG4	REMARKS
1	5NL-12459-00	GEAR, IMPELLER SHAFT	1	1	1	1	
2	90201-08512	WASHER, PLATE	1	1	1	1	
3	93440-07182	CIRCLIP	1	1	1	1	
4	5DH-12451-00	IMPELLER, WATER PUMP	1	1	1	1	
5	90201-08512	WASHER, PLATE	1	1	1	1	
6	93109-11073	OIL SEAL	1	1	1	1	
7	93102-12106	OIL SEAL (SD 12-22-5 HS)	1	1	1	1	
8	93306-00105	BEARING (B6001)	1	1	1	1	
9	5NL-12422-00	COVER, HOUSING	1	1	1	1	
10	5NL-12439-00	O-RING	1	1	1	1	
11	93604-10011	PIN, DOWEL	2	2	2	2	
12	90430-06014	GASKET	1	1	1	1	
13	95027-06025	BOLT, FLANGE	3	3	3	3	
14	95027-06065	BOLT, FLANGE	1	1	1	1	
15	95027-06012	BOLT, FLANGE	1	1	1	1	

FIG. 6 RADIATOR. HOSE

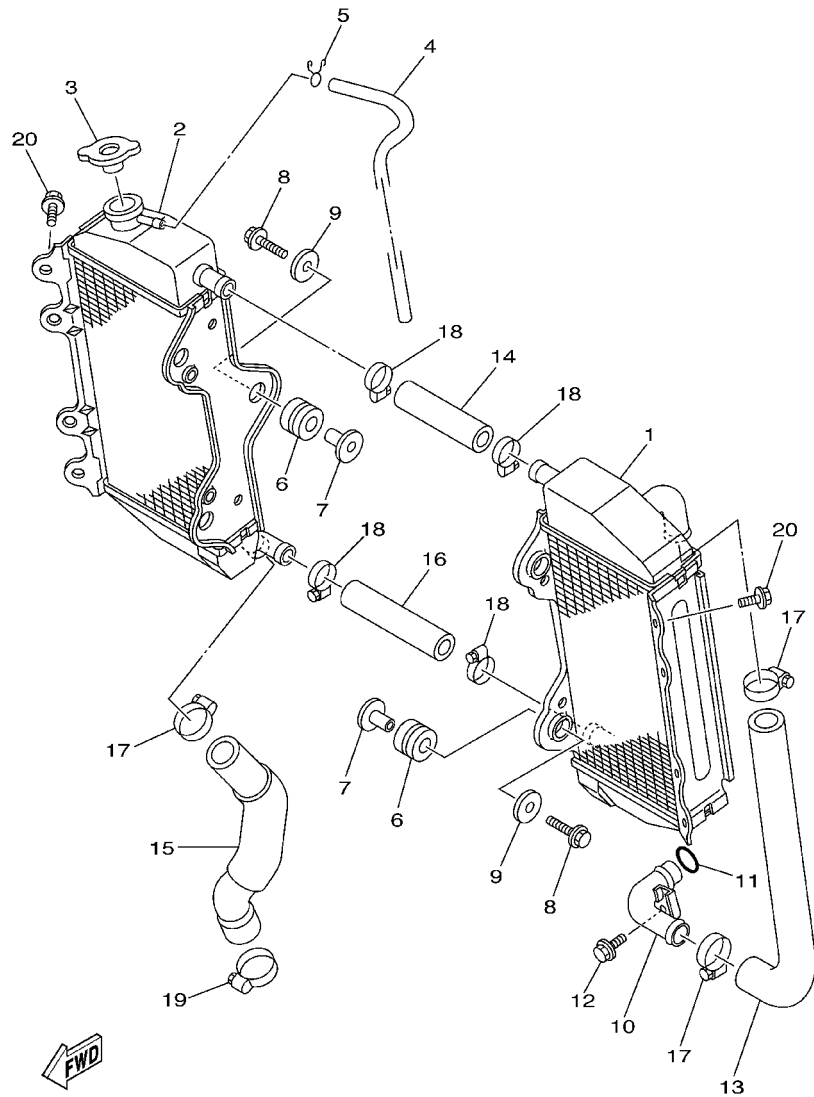

5NL1100-1060

REF. NO.	PART NO.	DESCRIPTION	5SG1	5SG2	5SG3	5SG4	REMARKS
1	5NL-1240A-00	RADIATOR ASSY	1	1	1	1	
2	5NL-12461-00	RADIATOR ASSY	1	1	1	1	
3	5HD-12462-00	CAP, RADIATOR	1	1	1	1	
4	91A20-05065	TUBE, FLEXIBLE VINYL	1	1	1	1	
5	90467-09006	CLIP	1	1	1	1	
6	90480-15528	GROMMET	6	6	6	6	
7	90387-0614M	COLLAR	6	6	6	6	
8	95027-06025	BOLT, FLANGE	6	6	6	6	
9	90201-06071	WASHER, PLATE	6	6	6	6	
10	5NL-12481-00	PIPE 1	1	1	1	1	
11	93210-15414	O-RING	1	1	1	1	
12	95027-06012	BOLT, FLANGE	1	1	1	1	
13	5SG-12576-00	HOSE 1	1	1	1	1	
14	5SG-12577-00	HOSE 2	1	1	1	1	
15	5SG-12578-00	HOSE 3	1	1	1	1	
16	5SG-12579-00	HOSE 4	1	1	1	1	
17	90450-25037	HOSE CLAMP ASSY	3	3	3	3	
18	90450-22017	HOSE CLAMP ASSY	4	4	4	4	
19	90450-32015	HOSE CLAMP ASSY	1	1	1	1	
20	95827-06010	BOLT, FLANGE	2	2	2	2	

FIG. 7 OIL PUMP

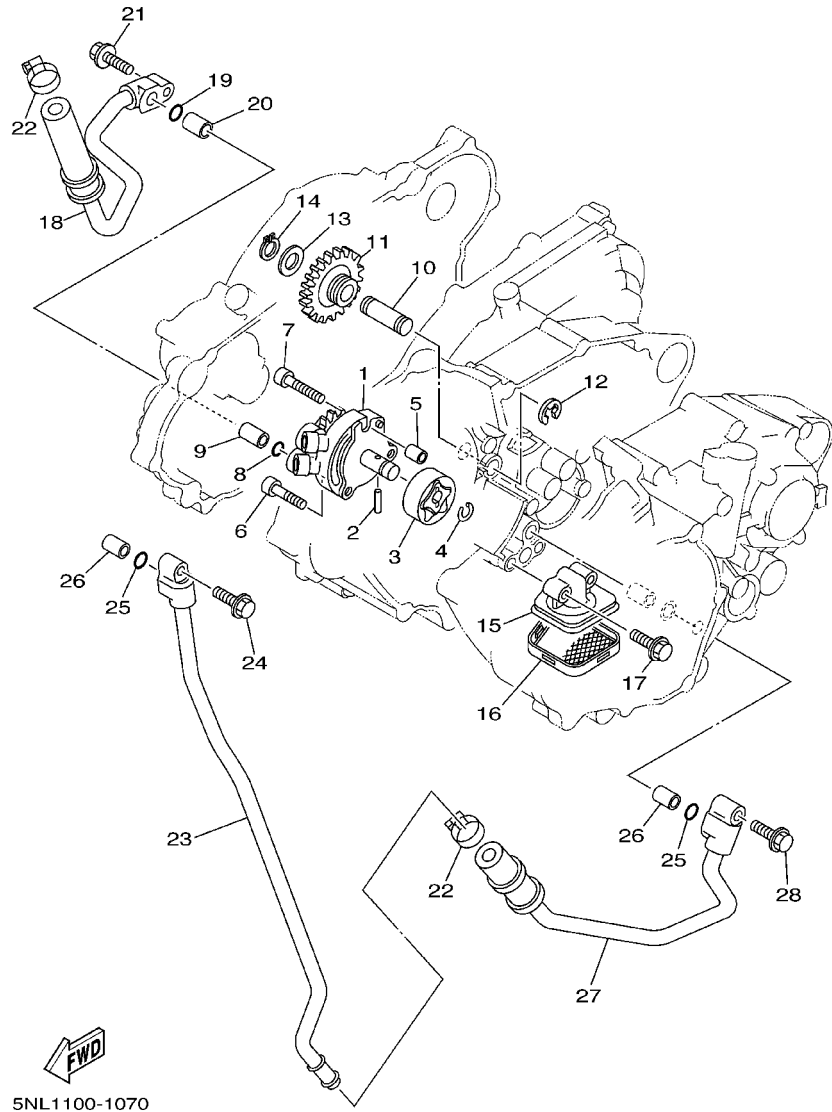

5NL1100-1070

REF. NO.	PART NO.	DESCRIPTION	5SG1	5SG2	5SG3	5SG4	REMARKS
1	5SG-13300-00	OIL PUMP ASSY	1	1	1	1	
2	93603-16219	PIN, DOWEL	1	1	1	1	
3	5NL-13320-00	ROTOR ASSY 2	1	1	1	1	
4	93440-10153	CIRCLIP	1	1	1	1	
5	99530-08012	PIN, DOWEL	1	1	1	1	
6	91317-06025	BOLT	2	2	2	2	
7	91314-06030	BOLT	1	1	1	1	
8	93210-10197	O-RING	1	1	1	1	
9	99530-10114	PIN, DOWEL	1	1	1	1	
10	5BE-13342-00	SHAFT, IDLE GEAR	1	1	1	1	
11	5NL-13341-00	GEAR, OIL PUMP IDLE	1	1	1	1	
12	99001-08600	CIRCLIP	1	1	1	1	
13	90201-12166	WASHER, PLATE	1	1	1	1	
14	99009-12400	CIRCLIP	1	1	1	1	
15	5NL-13412-00	HOUSING, STRAINER	1	1	1	1	
16	5NL-13411-00	STRAINER, OIL	1	1	1	1	
17	95027-06025	BOLT, FLANGE	2	2	2	2	
18	5NL-13464-00	HOSE, OIL 1	1	1	1	1	
19	93210-10197	O-RING	1	1	1	1	
20	99530-10114	PIN, DOWEL	1	1	1	1	
21	95027-06025	BOLT, FLANGE	1	1	1	1	
22	90450-22017	HOSE CLAMP ASSY	2	2	2	2	
23	5NL-13416-00	PIPE, OIL 1	1	1	1	1	
24	95024-06020	BOLT, FLANGE	1	1	1	1	
25	93210-10197	O-RING	2	2	2	2	
26	99530-10114	PIN, DOWEL	2	2	2	2	
27	5NL-13465-00	HOSE, OIL 2	1	1	1	1	

FIG. 7 OIL PUMP

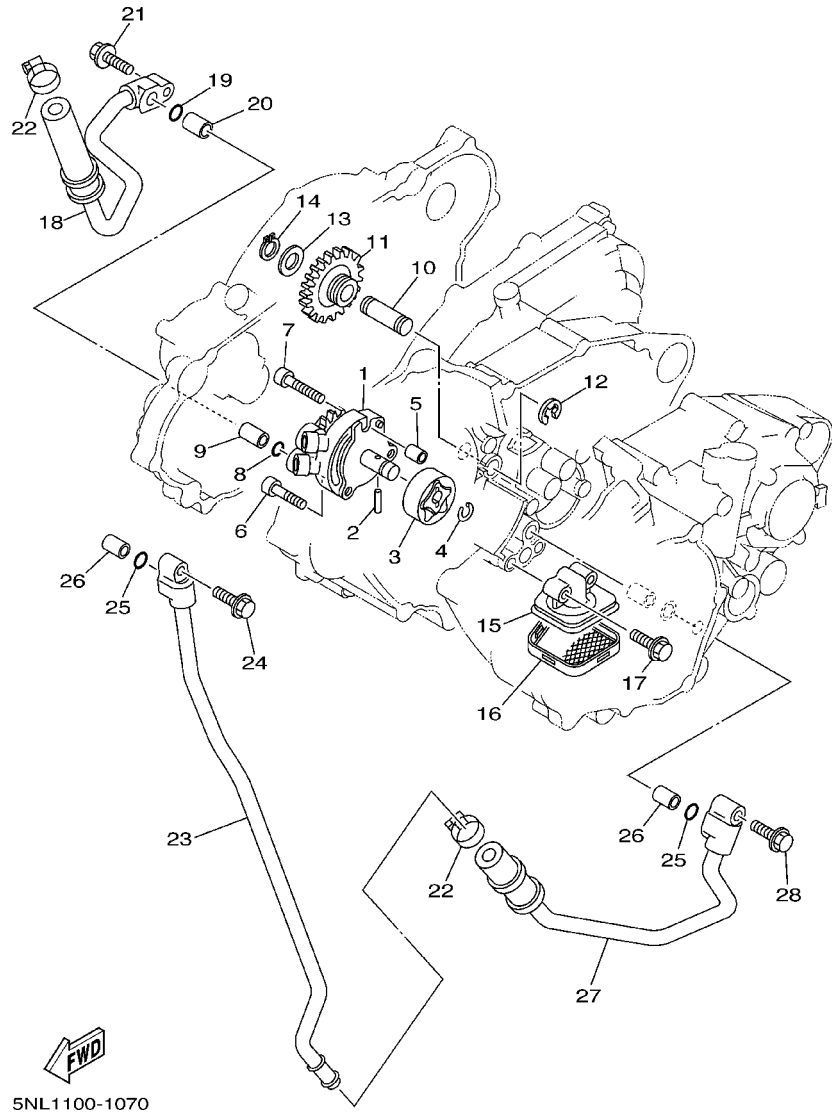

REF. NO.	PART NO.	DESCRIPTION	SSG1	SSG2	SSG3	SSG4	REMARKS
28	95027-06025	BOLT, FLANGE	1	1	1	1	

FIG. 8 OIL CLEANER

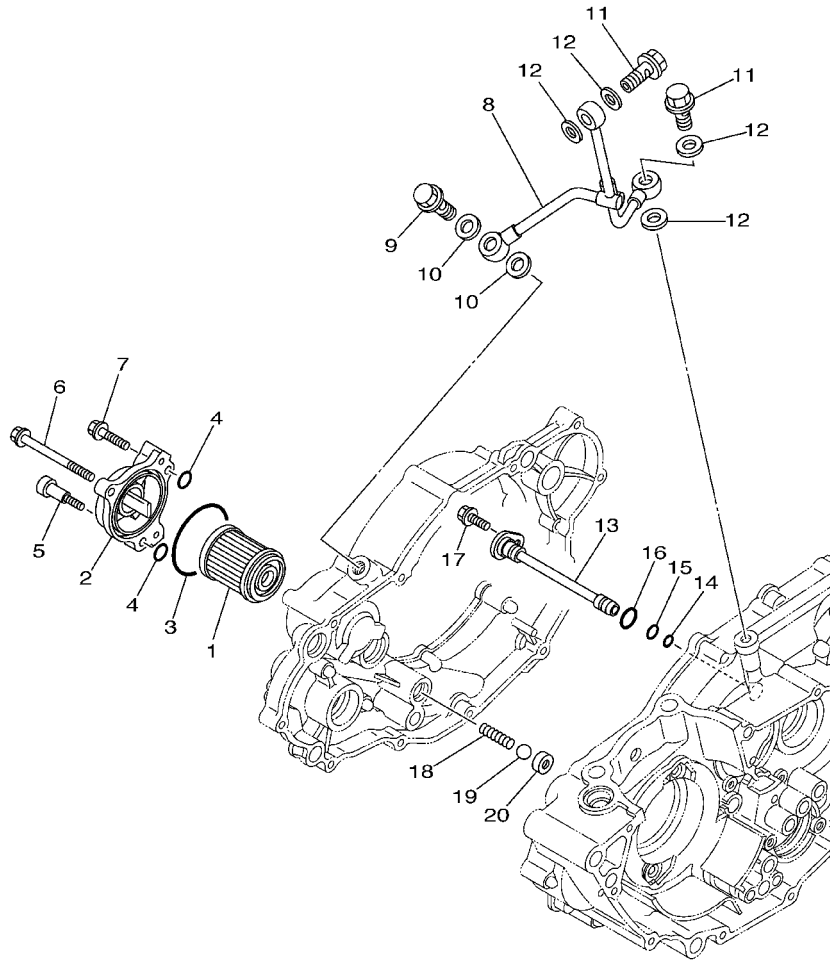

REF. NO.	PART NO.	DESCRIPTION	SSG1	SSG2	SSG3	SSG4	REMARKS
1	1UY-13440-02	ELEMENT ASSY, OIL CLEANER	1	1	1	1	
2	5BE-13447-00	COVER, OIL ELEMENT	1	1	1	1	
3	93210-47675	O-RING	1	1	1	1	
4	93210-07135	O-RING	3	3	3	3	
5	90109-065G2	BOLT	1	1	1	1	
6	95027-06065	BOLT, FLANGE	1	1	1	1	
7	95027-06025	BOLT, FLANGE	1	1	1	1	
8	5NL-13161-00	PIPE, DELIVERY 1	1	1	1	1	
9	90401-10159	BOLT, UNION	1	1	1	1	
10	90430-10188	GASKET	2	2	2	2	
11	90401-08038	BOLT, UNION	2	2	2	2	
12	90430-08119	GASKET	4	4	4	4	
13	5NL-13171-00	PIPE, DELIVERY 2	1	1	1	1	
14	93210-07003	O-RING	1	1	1	1	
15	93210-09008	O-RING	1	1	1	1	
16	93210-12759	O-RING	1	1	1	1	
17	95027-06012	BOLT, FLANGE	1	1	1	1	
18	90501-043E0	SPRING, COMPRESSION	1	1	1	1	
19	93503-08007	BALL	1	1	1	1	
20	583-13113-00	SEAT, CHECK BALL	1	1	1	1	

FWD
5NL1100-1080

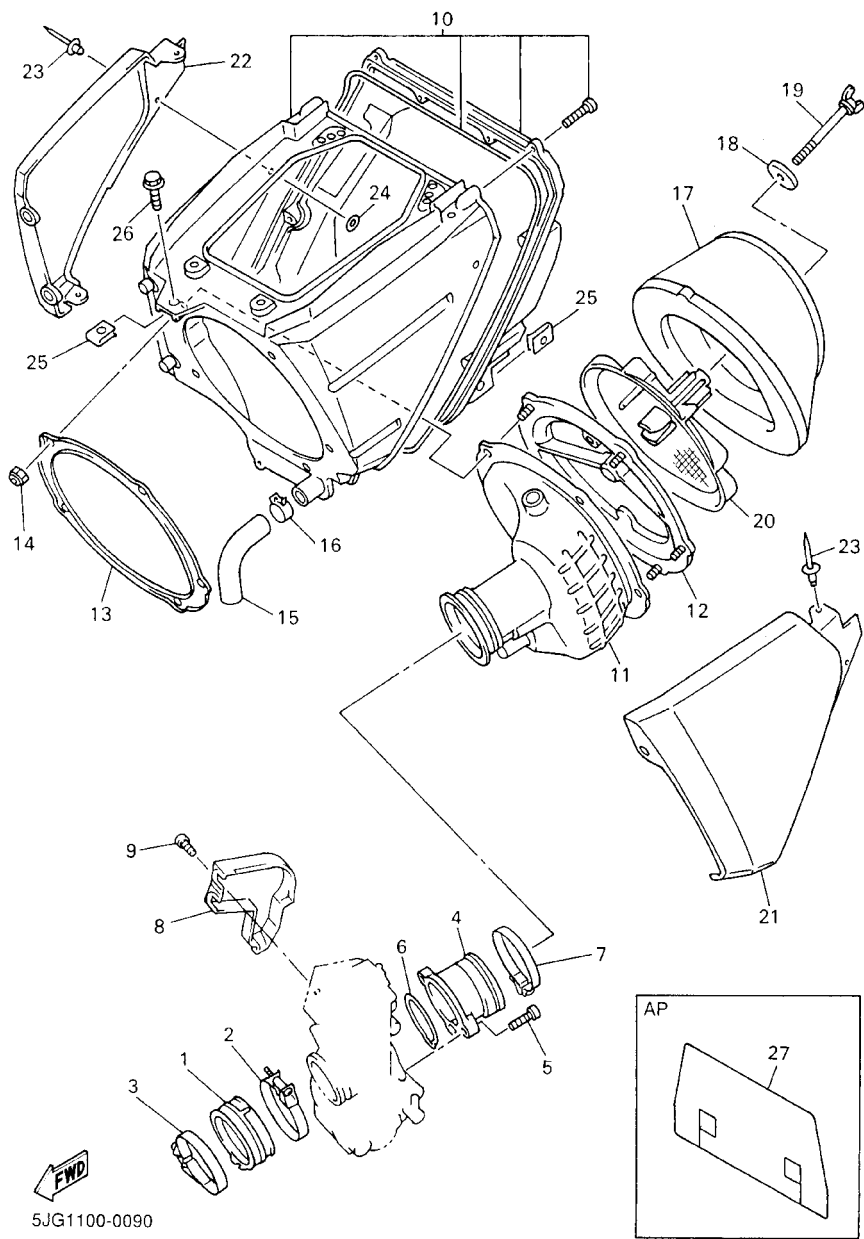
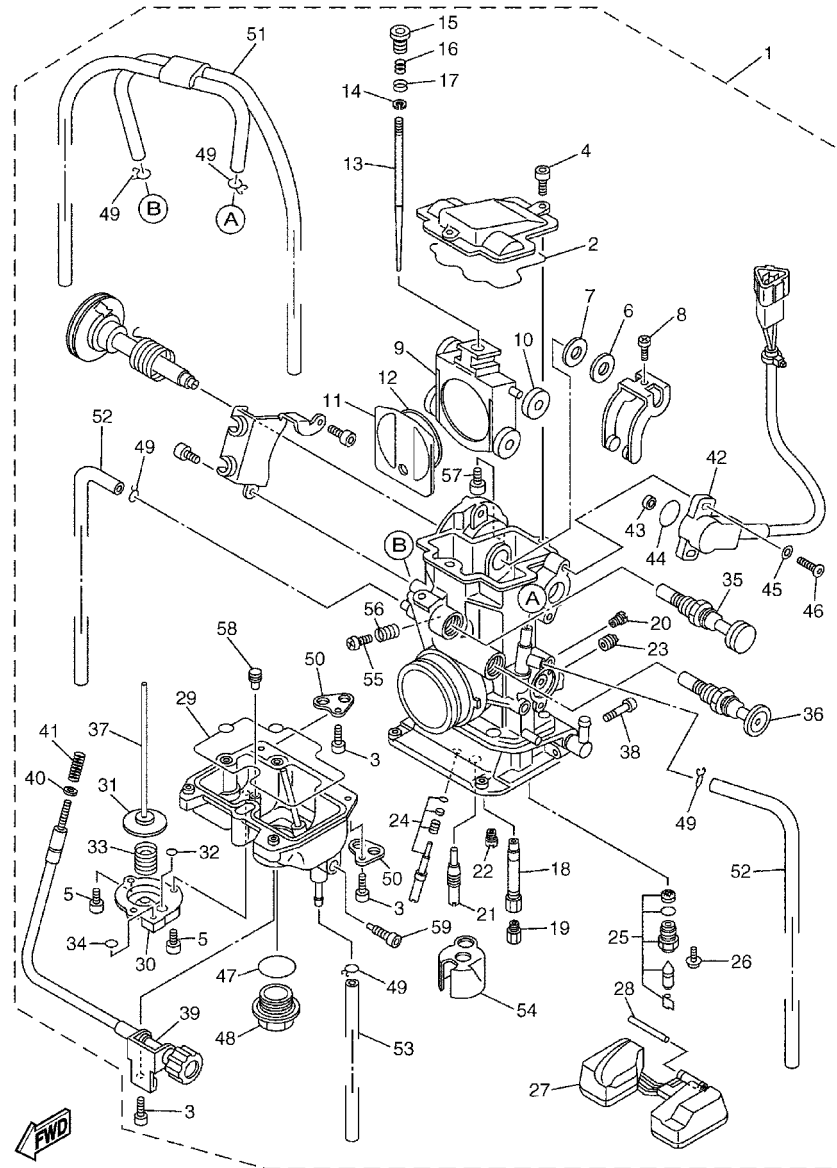

FIG. 9 INTAKE

REF. NO.	PART NO.	DESCRIPTION	SSG1	SSG2	SSG3	SSG4	REMARKS
1	5NL-13597-10	JOINT, CARBURETOR 3	1	1	1	1	
2	90450-57092	HOSE CLAMP ASSY	1	1	1	1	
3	90450-54002	HOSE CLAMP ASSY	1	1	1	1	
4	5JG-1440F-01	JOINT, AIR FILTER 1	1	1	1	1	
5	91317-05014	BOLT	2	2	2	2	
6	4FN-14561-00	O-RING	1	1	1	1	
7	90450-61001	HOSE CLAMP ASSY	1	1	1	1	
8	5JG-14293-01	COVER 1	1	1	1	1	
9	5JG-14428-00	BOLT	1	1	1	1	
10	5JG-14401-00	AIR CLEANER CASE ASSY	1	1	1	1	
11	5JG-14453-00	JOINT, AIR CLEANER 1	1	1	1	1	
12	3JD-14459-01	HOLDER, GUIDE	1	1	1	1	
13	5MV-14477-00	PLATE	1	1	1	1	
14	95607-05100	NUT, U	5	5	5	5	
15	5BE-1443E-00	PIPE, DRAIN	1	1	1	1	
16	90467-17089	CLIP	1	1	1	1	
17	4XM-14451-00	ELEMENT, AIR CLEANER	1	1	1	1	
18	90209-06096	WASHER	1	1	1	1	
19	90122-06035	BOLT, WING	1	1	1	1	
20	5BE-14458-00	GUIDE	1	1	1	1	
21	5BE-1441A-10	COVER, CLEANER CASE 1	1	1	1	1	
22	5BE-1441E-10	COVER, CLEANER CASE 2	1	1	1	1	
23	90267-32070	RIVET, BLIND	5	5	5	5	
24	90201-03313	WASHER, PLATE	5	5	5	5	
25	90183-06023	NUT, SPRING	2	2	2	2	
26	95027-06012	BOLT, FLANGE	1	1	1	1	
27	5JG-14417-00	COVER 1	1	1	1	1	AP

FIG. 10 CARBURETOR



5SG1100-2100

REF. NO.	PART NO.	DESCRIPTION	5SG1	5SG2	5SG3	5SG4	REMARKS
1	5SG-14101-00	CARBURETOR ASSY 1	1		1	1	
	5SG-14101-10	CARBURETOR ASSY 1		1			
2	5JG-14959-00	.GASKET	1	1	1	1	
3	91316-04012	.BOLT	4	4	4	4	
4	91316-04012	.BOLT	2	2	2	2	
5	91316-04008	.BOLT	3	3	3	3	
6	90202-08045	.WASHER, PLATE	1	1	1	1	
7	5JG-14951-00	.WASHER	1	1	1	1	
8	5JG-14522-00	.SCREW, ADJUST	1	1	1	1	
9	5JG-14388-00	.VALVE, VACUUM CONTROL	1	1	1	1	
10	3TJ-14267-40	.ROLLER	1	1	1	1	
11	5JG-14546-01	.VALVE, NEEDLE	1	1	1	1	
12	4FN-14997-00	.SEAL	1	1	1	1	
13	5JG-14916-EP	.NEEDLE (#OBEKP)	1	1	1	1	STD
	5JG-14916-EL	.NEEDLE (#OBEKL)	1	1	1	1	AP
	5JG-14916-EM	.NEEDLE (#OBEKM)	1	1	1	1	AP
	5JG-14916-EN	.NEEDLE (#OBEKN)	1	1	1	1	AP
	5JG-14916-E1	.NEEDLE (#OBEKQ)	1	1	1	1	AP
	5JG-14916-ER	.NEEDLE (#OBEKR)	1	1	1	1	AP
	5JG-14916-ES	.NEEDLE (#OBEKS)	1	1	1	1	AP
14	3TJ-14159-40	.CLIP	1	1	1	1	
15	5JG-14521-00	.SCREW, ADJUST	1	1	1	1	
16	5JG-14275-00	.SPRING	1	1	1	1	
17	5JG-14264-00	.COLLAR	1	1	1	1	
18	5JG-14947-00	.NOZZLE, MAIN	1	1	1	1	
19	4MX-14943-93	.JET, MAIN (#178)	1	1	1	1	STD
	4MX-14943-40	.JET, MAIN (#165)	1	1	1	1	AP

FIG. 10 CARBURETOR

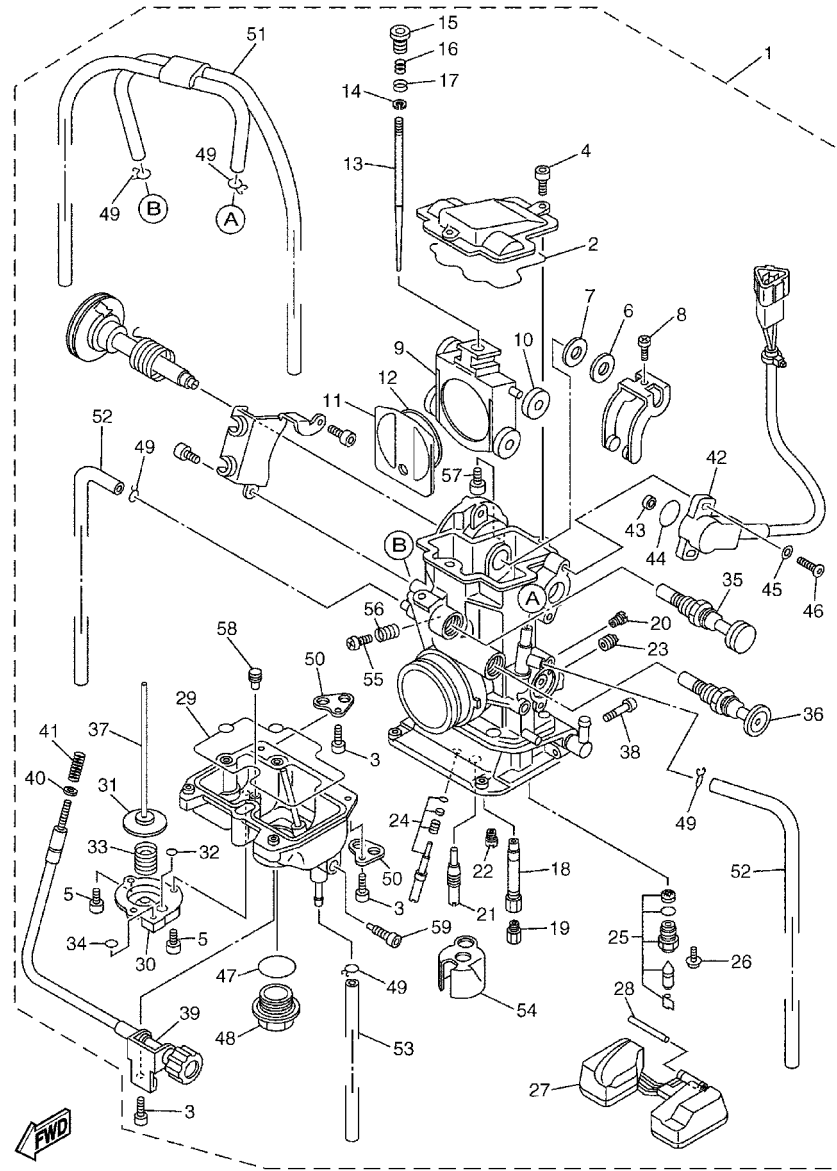

5SG1100-2100

REF. NO.	PART NO.	DESCRIPTION	5SG1	5SG2	5SG3	5SG4	REMARKS
19	4MX-14943-91	.JET, MAIN (#168)	1	1	1	1	AP
	4MX-14943-41	.JET, MAIN (#170)	1	1	1	1	AP
	4MX-14943-92	.JET, MAIN (#172)	1	1	1	1	AP
	4MX-14943-42	.JET, MAIN (#175)	1	1	1	1	AP
	4MX-14943-43	.JET, MAIN (#180)	1	1	1	1	AP
	4MX-14943-94	.JET, MAIN (#182)	1	1	1	1	AP
	4MX-14943-44	.JET, MAIN (#185)	1	1	1	1	AP
	4MX-14943-95	.JET, MAIN (#188)	1	1	1	1	AP
	4MX-14943-45	.JET, MAIN (#190)	1	1	1	1	AP
20	3TJ-14943-47	.JET (#200)	1	1	1	1	
21	4MX-14948-03	.JET, SLOW (#40)	1	1	1	1	STD
	4MX-14948-01	.JET, SLOW (#35)	1	1	1	1	AP
	4MX-14948-02	.JET, SLOW (#38)	1	1	1	1	AP
	4MX-14948-04	.JET, SLOW (#42)	1	1	1	1	AP
	4MX-14948-05	.JET, SLOW (#45)	1	1	1	1	AP
	4MX-14948-06	.JET, SLOW (#48)	1	1	1	1	AP
	4MX-14948-07	.JET, SLOW (#50)	1	1	1	1	AP
22	3TJ-1494F-16	.JET (#72)	1	1	1	1	STD
	3TJ-1494F-12	.JET (#62)	1	1	1	1	AP
	3TJ-1494F-13	.JET (#65)	1	1	1	1	AP
	3TJ-1494F-14	.JET (#68)	1	1	1	1	AP
	3TJ-1494F-15	.JET (#70)	1	1	1	1	AP
	3TJ-1494F-17	.JET (#75)	1	1	1	1	AP
	3TJ-1494F-18	.JET (#78)	1	1	1	1	AP
	3TJ-1494F-19	.JET (#80)	1	1	1	1	AP
	3TJ-1494F-20	.JET (#82)	1	1	1	1	AP
23	7A9-14943-27	.JET (#100)	1	1	1	1	

FIG. 10 CARBURETOR

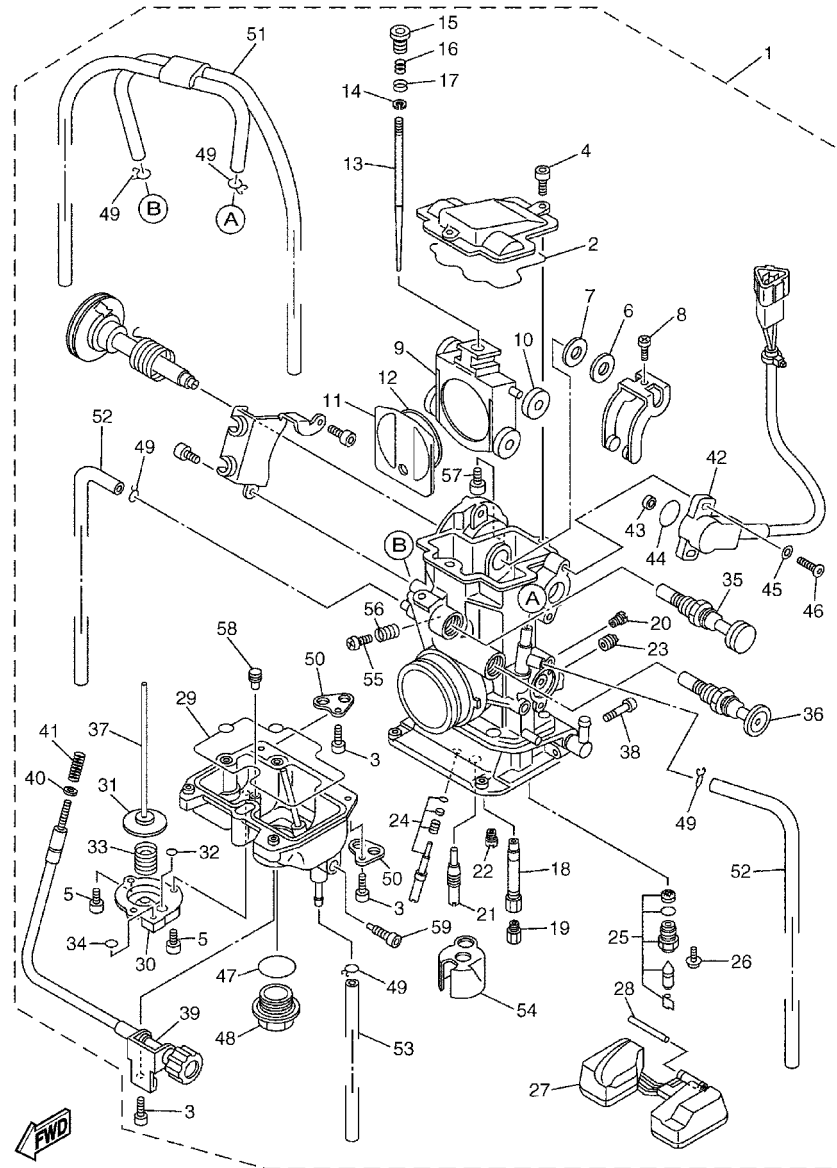

5SG1100-2100

REF. NO.	PART NO.	DESCRIPTION	5SG1	5SG2	5SG3	5SG4	REMARKS
24	3TJ-14105-40	.PILOT SCREW SET	1	1	1	1	
25	5BE-14107-00	.NEEDLE VALVE SET	1	1	1	1	
26	5BE-14216-00	.SCREW	1	1	1	1	
27	4SR-14985-00	.FLOAT	1	1	1	1	
28	676-14548-00	.PIN, FLOAT ARM	1	1	1	1	
29	5JG-14984-00	.GASKET, FLOAT CHAMBER	1	1	1	1	
30	3TJ-14293-40	.COVER 1	1	1	1	1	
31	5JG-14940-76	.DIAPHRAGM ASSY	1	1	1	1	STD
	5JG-14940-16	.DIAPHRAGM ASSY	1	1	1	1	AP
	5JG-14940-17	.DIAPHRAGM ASSY	1	1	1	1	AP
	5JG-14940-18	.DIAPHRAGM ASSY	1	1	1	1	AP
32	3TJ-14536-40	.GASKET	1	1	1	1	
33	3TJ-14933-40	.SPRING, DIAPHRAGM	1	1	1	1	
34	6H4-14561-00	.O-RING	1	1	1	1	
35	5JG-14171-00	.PLUNGER, STARTER	1	1	1	1	
36	5JG-14371-00	.PLUNGER, STARTER	1	1	1	1	
37	5JG-14379-00	.ROD, STARTER	1	1	1	1	
38	3TJ-14325-40	.SCREW, PAN HEAD	1	1	1	1	
39	5JG-14922-00	.SCREW, THROTTLE	1	1	1	1	
40	90201-08410	.WASHER, PLATE	1	1	1	1	
41	4FN-14934-00	.SPRING, THROTTLE STOP	1	1	1	1	
42	5JG-85885-00	.THROTTLE SENSOR ASSY	1	1	1	1	
43	5BE-14449-00	.COLLAR	1	1	1	1	
44	5BE-14562-00	.O-RING	1	1	1	1	
45	4YR-14557-00	.WASHER	2	2	2	2	
46	4YR-14216-00	.SCREW	2	2	2	2	
47	4MX-14561-00	.O-RING	1	1	1	1	

FIG. 10 CARBURETOR

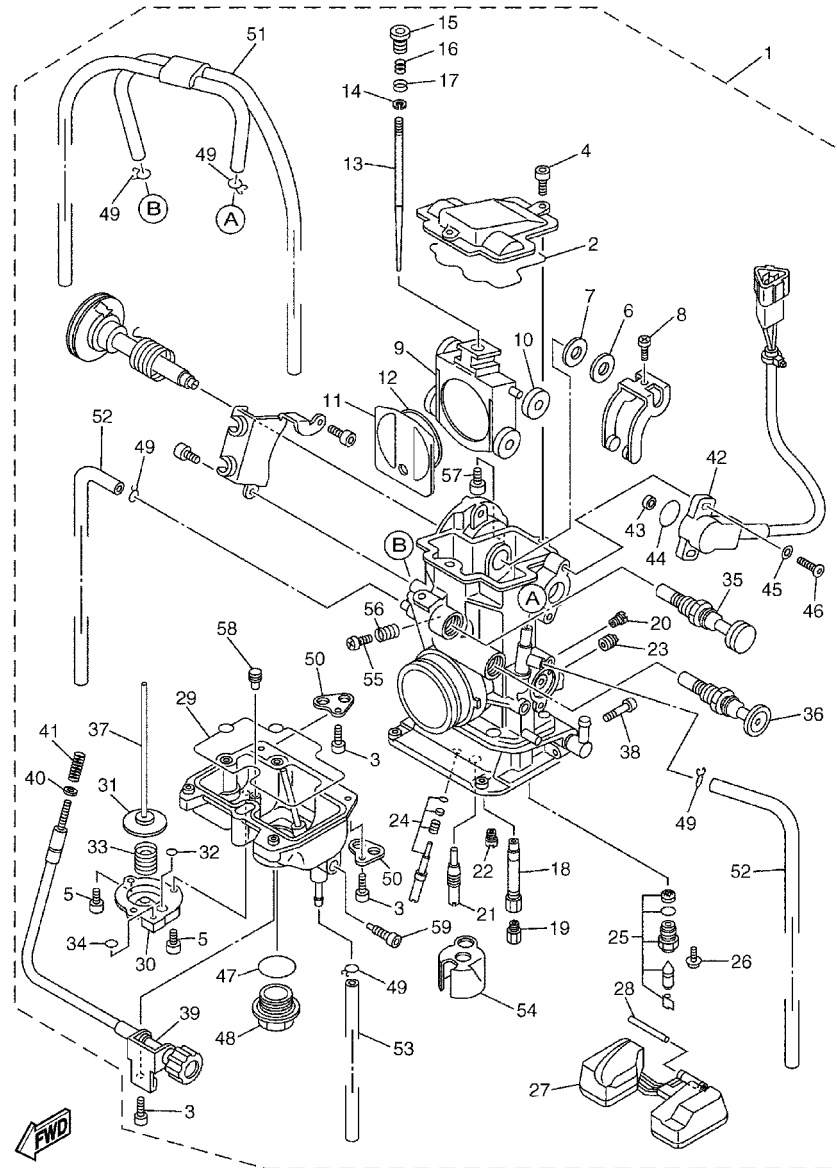

5SG1100-2100

REF. NO.	PART NO.	DESCRIPTION	5SG1	5SG2	5SG3	5SG4	REMARKS
48	4MX-14115-00	.PLUG, SCREW	1	1	1	1	
49	3TJ-14137-40	.CLIP	5	5	5	5	
50	5BE-14146-00	.PLATE	2	2	2	2	
51	5NL-14196-00	.PIPE COMP.	1	1	1	1	
52	5JG-14197-00	.PIPE	2	2	2	2	
53	5JG-14987-00	.HOSE	1	1	1	1	
54	5JG-14346-00	.PLATE	1	1	1	1	
55	5JG-14565-00	.SCREW	1	1	1	1	
56	5JG-14531-00	.SPRING, ADJUST SCREW	1	1	1	1	
57	5NL-14591-00	.SCREW	1	1	1	1	
58	4JT-1494F-27	.JET(#100)	1		1	1	STD
	4JT-1494F-15	.JET (#70)	1		1	1	AP
	4JT-1494F-19	.JET (#80)	1		1	1	AP
	4JT-1494F-23	.JET (#90)	1		1	1	AP
	4JT-1494F-29	.JET(#110)	1		1	1	AP
	4JT-1494F-31	.JET(#120)	1		1	1	AP
	4JT-1494F-33	.JET(#130)	1		1	1	AP
	4JT-1494F-25	.JET (#95)		1			STD
	4JT-1494F-13	.JET (#65)		1			AP
	4JT-1494F-17	.JET (#75)		1			AP
	4JT-1494F-21	.JET (#85)		1			AP
	4JT-1494F-28	.JET (#105)		1			AP
	4JT-1494F-30	.JET (#115)		1			AP
	4JT-1494F-32	.JET (#125)		1			AP
59	3TJ-14191-40	.PLUG, DRAIN	1	1	1	1	

FIG. 11 EXHAUST

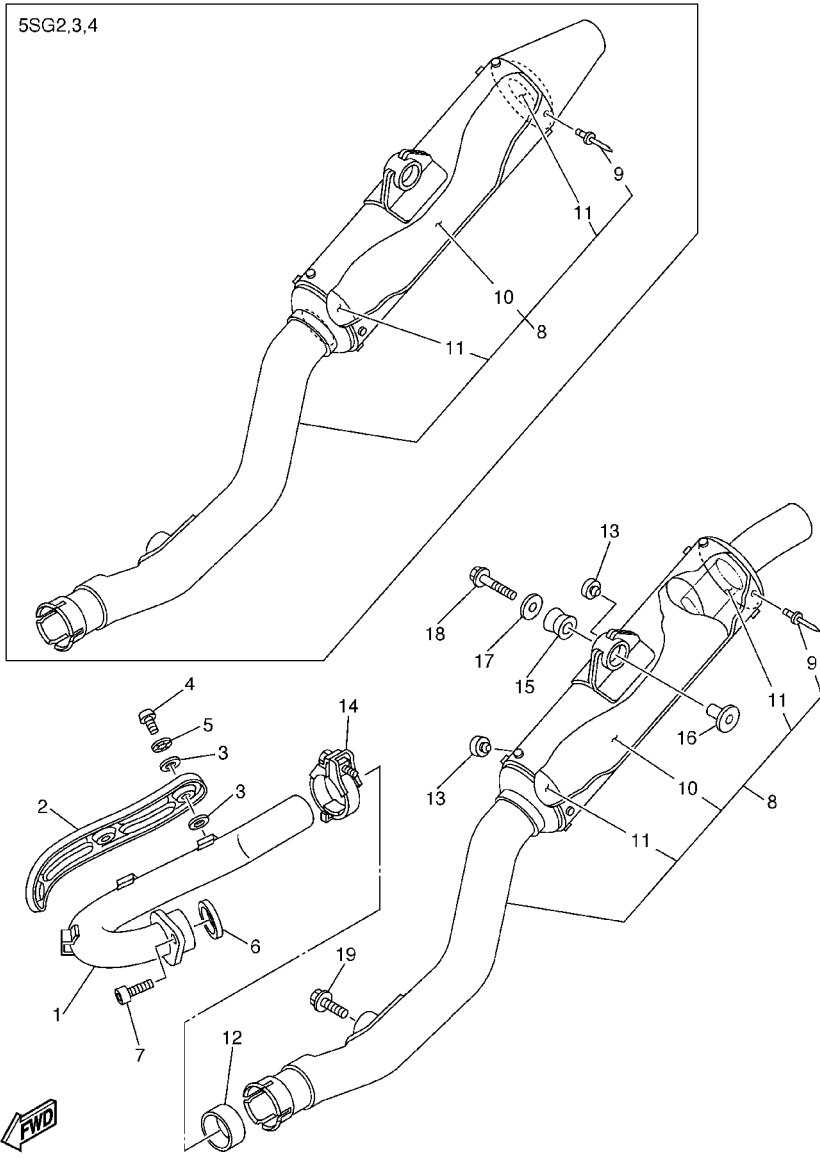

REF. NO.	PART NO.	DESCRIPTION	5SG1	5SG2	5SG3	5SG4	REMARKS
1	5NL-14611-00	PIPE, EXHAUST 1	1	1	1	1	
2	5NL-14628-00	PROTECTOR, EXHAUST PIPE	1	1	1	1	
3	4BD-14766-00	WASHER, PROTECTOR	6	6	6	6	
4	98980-06008	SCREW, BIND	3	3	3	3	
5	90206-06090	WASHER, WAVE	3	3	3	3	
6	5NL-14613-00	GASKET, EXHAUST PIPE	1	1	1	1	
7	91317-08020	BOLT	1	1	1	1	
8	5NL-14753-00	SILENCER, EXHAUST	1				
	5NL-14753-10	SILENCER, EXHAUST		1	1	1	
9	90267-48121	.RIVET, BLIND	8	8	8	8	
10	5NL-1469A-00	.FIBER	1	1	1	1	
11	5BE-1469E-00	.FIBER	2	2	2	2	
12	3VD-14755-00	GASKET, SILENCER	1	1	1	1	
13	22W-24181-00	DAMPER, LOCATING 1	2	2	2	2	
14	5NL-14788-00	BAND, SILENCER	1	1	1	1	
15	5BE-14747-00	DAMPER, MUFFLER	1	1	1	1	
16	90387-0814J	COLLAR	1	1	1	1	
17	90201-081R9	WASHER, PLATE	1	1	1	1	
18	95817-08030	BOLT, FLANGE	1	1	1	1	
19	95817-08016	BOLT, FLANGE	1	1	1	1	

FIG. 12 CRANKCASE

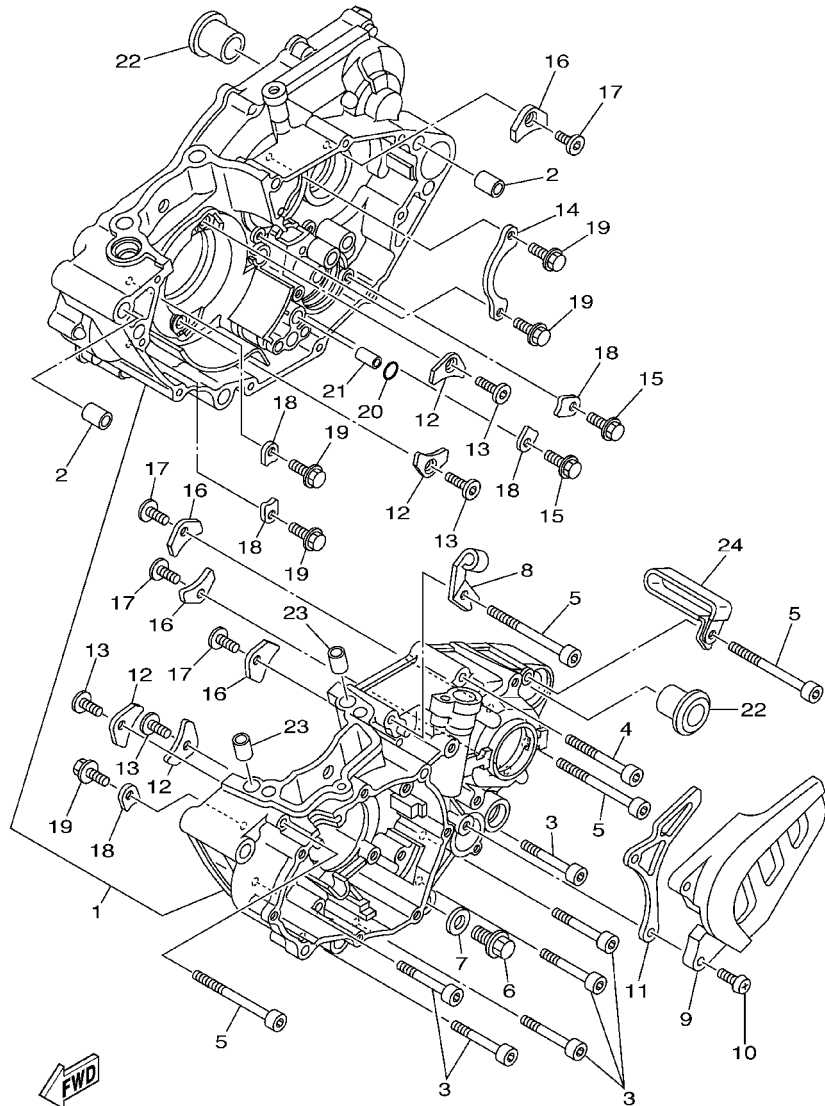

5NL1100-1120

REF. NO.	PART NO.	DESCRIPTION	SSG1	SSG2	SSG3	SSG4	REMARKS
1	5SG-15150-00	CRANKCASE ASSY	1	1	1	1	
2	93612-16254	PIN, DOWEL	2	2	2	2	
3	91317-06045	BOLT	6	6	6	6	
4	91317-06055	BOLT	1	1	1	1	
5	91317-06070	BOLT	4	4	4	4	
6	95027-10016	BOLT, FLANGE	1	1		1	
	5NL-28331-00	BOLT, LEG SHIELD			1		
7	90430-10188	GASKET	1	1	1	1	
8	5NL-15441-01	HOLDER, CLUTCH CABLE	1	1	1	1	
9	5BE-15421-00	COVER, CRANKCASE 2	1	1	1	1	
10	98507-06025	SCREW, PAN HEAD	2	2	2	2	
11	5NL-17466-00	GUIDE, CHAIN	1	1	1	1	
12	5BE-15383-01	PLATE, BEARING COVER	4	4	4	4	
13	90149-06126	SCREW	4	4	4	4	
14	5NL-15388-00	PLATE, BEARING COVER	1	1	1	1	
15	90105-06553	BOLT, FLANGE	2	2	2	2	
16	4JT-15381-01	PLATE, BEARING COVER	4	4	4	4	
17	90149-06326	SCREW	4	4	4	4	
18	5DH-18562-00	PLATE, STOPPER 2	5	5	5	5	
19	90105-06553	BOLT, FLANGE	5	5	5	5	
20	93210-10197	O-RING	1	1	1	1	
21	99530-10114	PIN, DOWEL	1	1	1	1	
22	90387-18007	COLLAR	2	2	2	2	
23	99530-10116	PIN, DOWEL	2	2	2	2	
24	90465-10013	CLAMP	1	1	1	1	

FIG. 13 CRANKCASE COVER 1

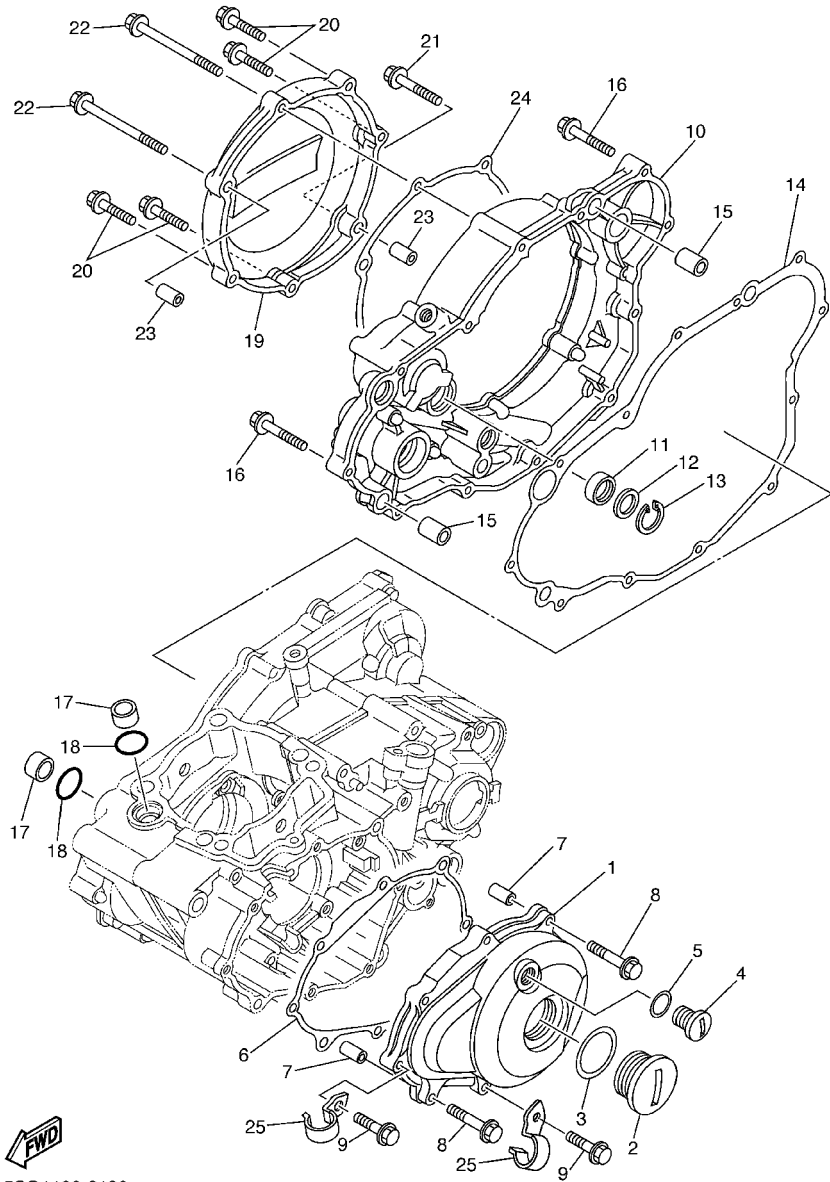

5SG1100-2130

REF. NO.	PART NO.	DESCRIPTION	5SG1	5SG2	5SG3	5SG4	REMARKS
1	5NL-15411-00	COVER, CRANKCASE 1	1	1	1	1	
2	90340-32123	PLUG, STRAIGHT SCREW	1	1	1	1	
3	93210-32172	O-RING	1	1	1	1	
4	90340-14128	PLUG, STRAIGHT SCREW	1	1	1	1	
5	93210-14369	O-RING	1	1	1	1	
6	5NL-15451-00	GASKET, CRANKCASE COVER 1	1	1	1	1	
7	99530-08016	PIN, DOWEL	2	2	2	2	
8	95027-06035	BOLT, FLANGE	2	2	2	2	
9	95027-06025	BOLT, FLANGE	6	6	6	6	
10	5NL-15431-00	COVER, CRANKCASE 3	1	1	1	1	
11	93101-14164	OIL SEAL	1	1	1	1	
12	90201-15701	WASHER, PLATE (1.0T)	1	1	1	1	
13	99009-22500	CIRCLIP	1	1	1	1	
14	5NL-15462-00	GASKET, CRANKCASE COVER 3	1	1	1	1	
15	91812-16001	PIN, DOWEL	2	2	2	2	
16	95027-06035	BOLT, FLANGE	8	8	8	8	
17	5NL-12564-00	PIPE, WATER	2	2	2	2	
18	93210-16716	O-RING	2	2	2	2	
19	5NL-15415-00	COVER 1	1	1	1	1	
20	95027-06025	BOLT, FLANGE	4	4	4	4	
21	95027-06035	BOLT, FLANGE	1	1	1	1	
22	90105-065A1	BOLT, FLANGE	2	2	2	2	
23	99530-08016	PIN, DOWEL	2	2	2	2	
24	5NL-15453-00	GASKET 1	1	1	1	1	
25	90465-08029	CLAMP	2	2	2	2	

FIG. 14 STARTER

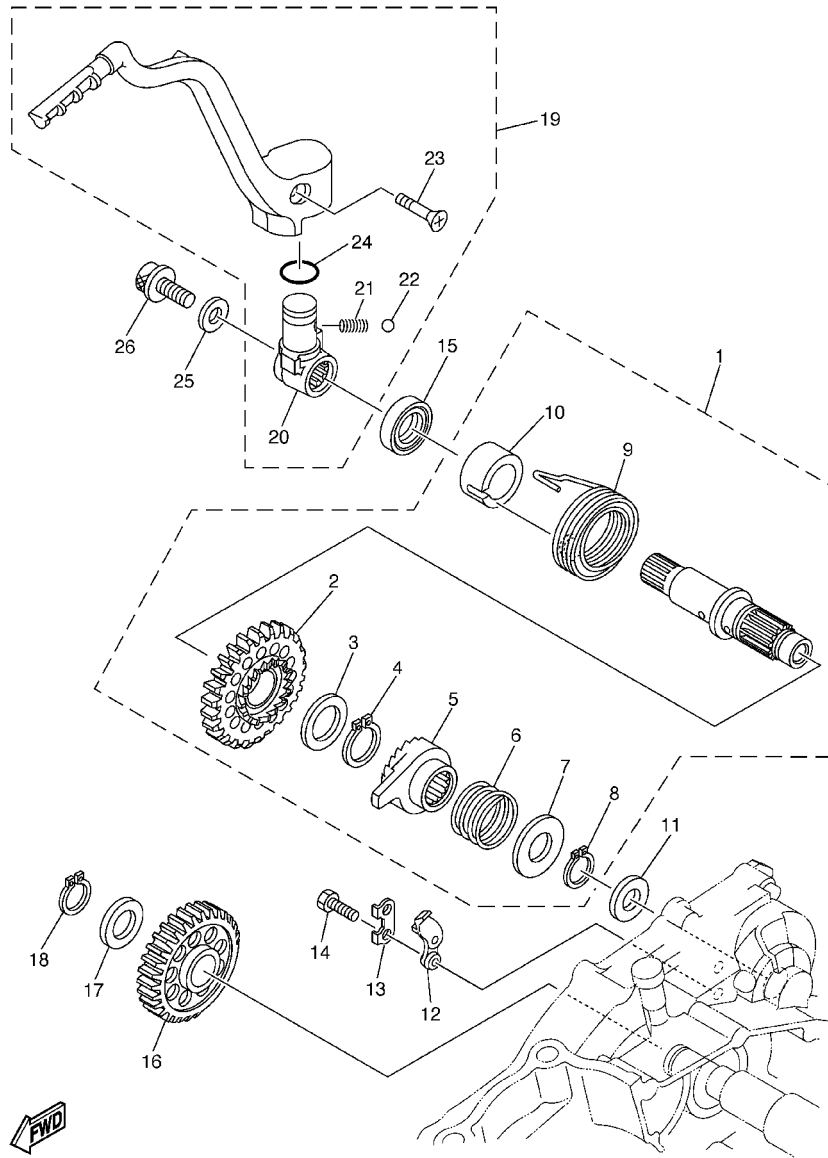

5SG1100-2140

REF. NO.	PART NO.	DESCRIPTION	5SG1	5SG2	5SG3	5SG4	REMARKS
1	5NL-15601-00	KICK SHAFT ASSY	1	1	1	1	
2	5NL-15641-00	.GEAR, KICK	1	1	1	1	
3	90201-20685	.WASHER, PLATE (0.5T)	1	1	1	1	
4	93410-20038	.CIRCLIP	1	1	1	1	
5	4GY-15671-00	.WHEEL, RATCHET	1	1	1	1	
6	90501-16016	.SPRING, COMPRESSION	1	1	1	1	
7	90201-167P7	.WASHER, PLATE	1	1	1	1	
8	99009-16400	.CIRCLIP	1	1	1	1	
9	90508-30743	.SPRING, TORSION	1	1	1	1	
10	5NL-15664-00	.GUIDE, SPRING	1	1	1	1	
11	90201-162H4	WASHER, PLATE	1	1	1	1	
12	5SG-15668-00	STOPPER	1	1	1	1	
13	214-15686-00	WASHER, LOCK	1	1	1	1	
14	90101-06001	BOLT	2	2	2	2	
15	93102-18278	OIL SEAL	1	1	1	1	
16	5NL-15651-00	GEAR, KICK IDLE	1	1	1	1	
17	90201-177G4	WASHER, PLATE	1	1	1	1	
18	99009-17400	CIRCLIP	1	1	1	1	
19	5NL-15620-00	KICK CRANK ASSY	1	1	1	1	
20	5NL-15621-00	.BOSS, KICK CRANK	1	1	1	1	
21	90501-12081	.SPRING, COMPRESSION	1	1	1	1	
22	93507-32009	.BALL	1	1	1	1	
23	90152-06010	.SCREW, COUNTERSUNK	1	1	1	1	
24	93210-17570	.O-RING	1	1	1	1	
25	90201-08326	WASHER, PLATE	1	1	1	1	
26	90109-082G0	BOLT	1	1	1	1	

FIG. 15 CLUTCH

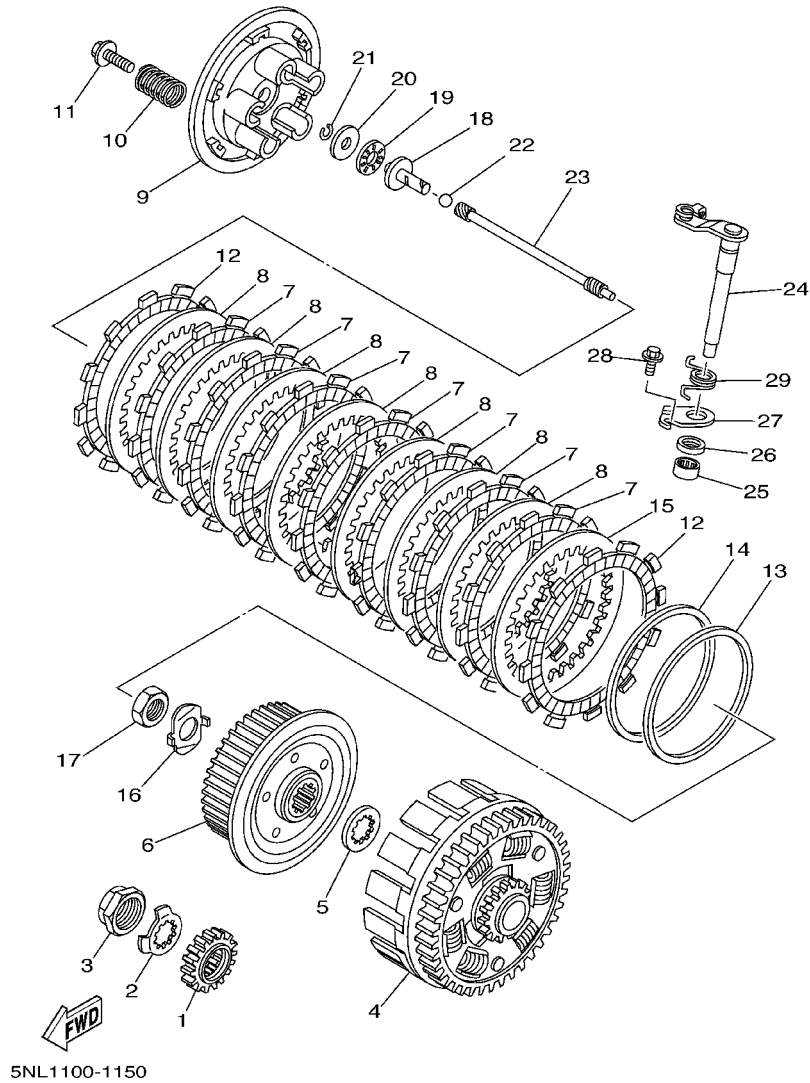

REF. NO.	PART NO.	DESCRIPTION	SSG1	SSG2	SSG3	SSG4	REMARKS
1	5NL-16111-00	GEAR, PRIMARY DRIVE	1	1	1	1	
2	90215-20003	WASHER, LOCK	1	1	1	1	
3	90179-18001	NUT	1	1	1	1	
4	5NL-16150-10	PRIMARY DRIVEN GEAR COMP.	1	1	1	1	
5	5NL-16154-00	PLATE, THRUST 1	1	1	1	1	
6	5NL-16371-00	BOSS, CLUTCH	1	1	1	1	
7	5DH-16321-00	PLATE, FRICTION	7	7	7	7	
8	5NL-16325-00	PLATE, CLUTCH 2	7	7	7	7	
9	5HD-16351-00	PLATE, PRESSURE 1	1	1	1	1	
10	90501-224J9	SPRING, COMPRESSION	5	5	5	5	
11	90159-06092	SCREW, WITH WASHER	5	5	5	5	
12	3XJ-16321-00	PLATE, FRICTION	2	2	2	2	
13	5NL-16384-00	PLATE, SEAT	1	1	1	1	
14	5NL-16383-10	SPRING, CLUTCH BOSS	1	1	1	1	
15	5NL-16325-10	PLATE, CLUTCH 2	1	1	1	1	
16	90215-16289	WASHER, LOCK	1	1	1	1	
17	90170-16326	NUT	1	1	1	1	
18	5NL-16356-00	ROD, PUSH 1	1	1	1	1	
19	93340-21008	BEARING	1	1	1	1	
20	90201-080H1	WASHER, PLATE	1	1	1	1	
21	93440-07182	CIRCLIP	1	1	1	1	
22	93511-32027	BALL	1	1	1	1	
23	5NL-16357-00	ROD, PUSH 2	1	1	1	1	
24	5JG-16381-00	PUSH LEVER COMP.	1	1	1	1	
25	93317-11287	BEARING	1	1	1	1	
26	93102-12224	OIL SEAL	1	1	1	1	
27	4JT-16384-00	PLATE, SEAT	1	1	1	1	

FIG. 15 CLUTCH

REF. NO.	PART NO.	DESCRIPTION	SSG1	SSG2	SSG3	SSG4	REMARKS
28	95027-06010	BOLT, FLANGE	1	1	1	1	
29	90508-142B5	SPRING, TORSION	1	1	1	1	

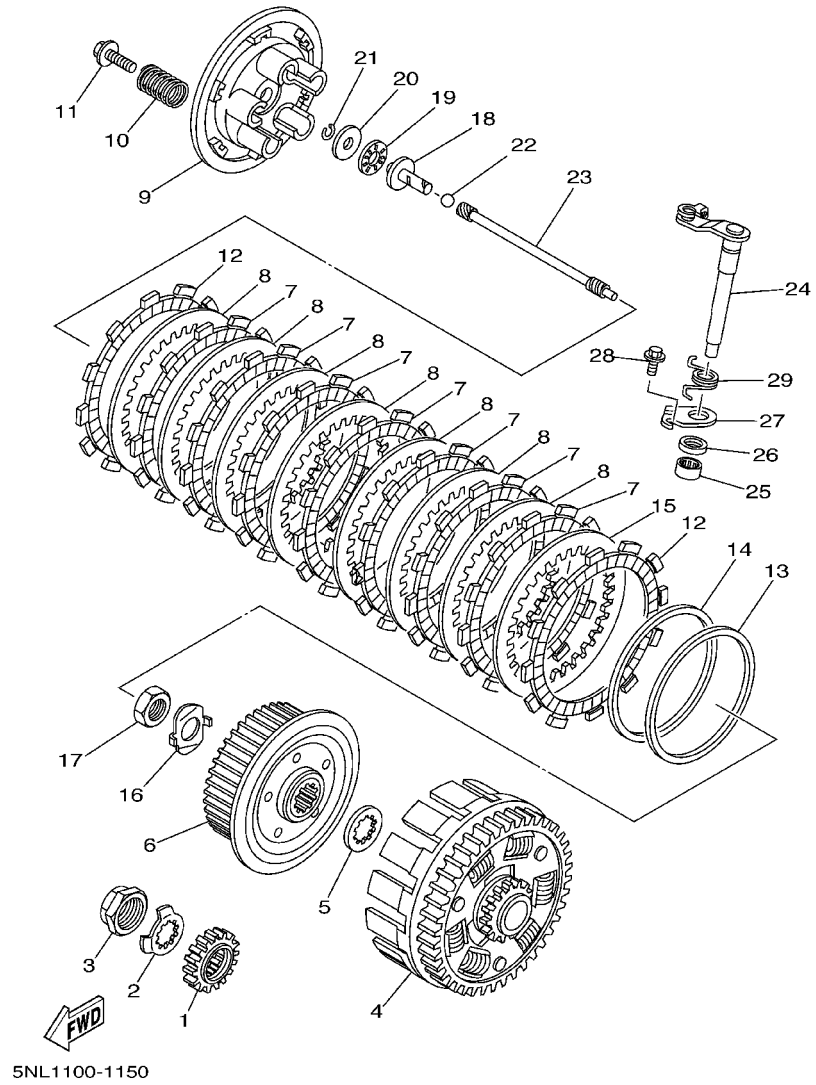
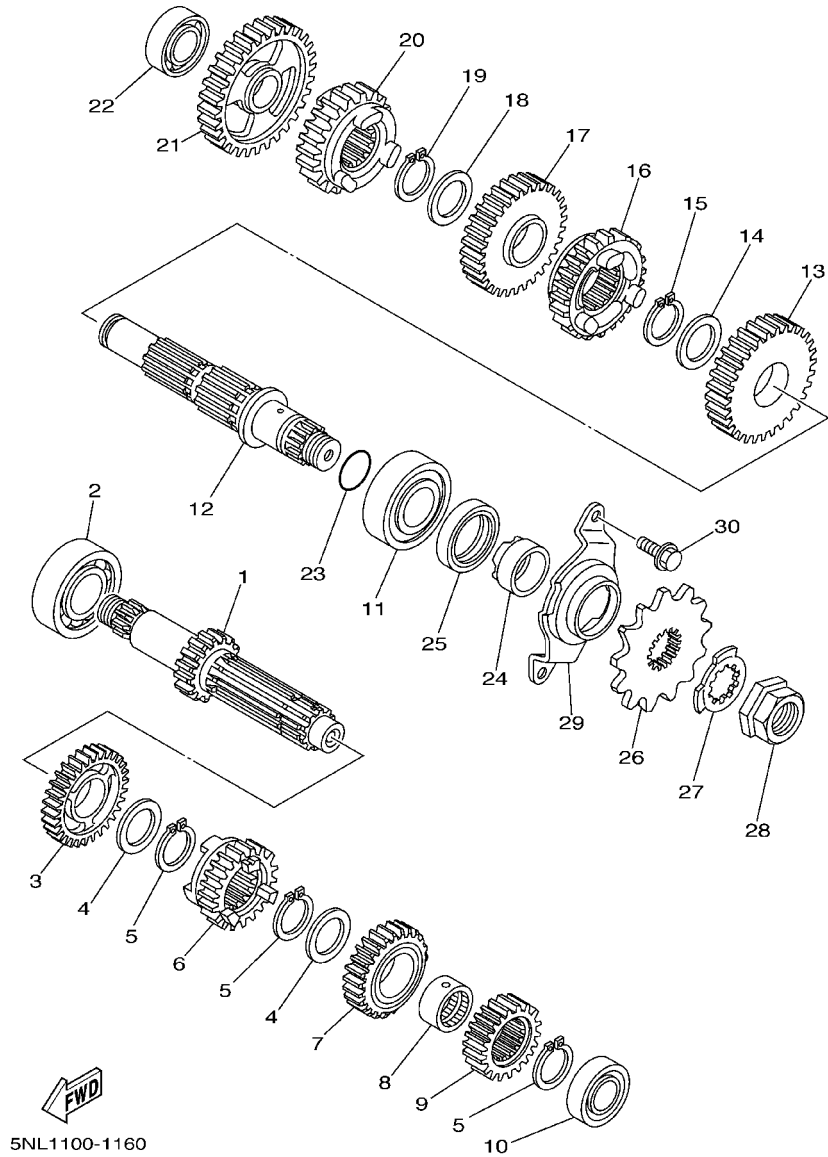
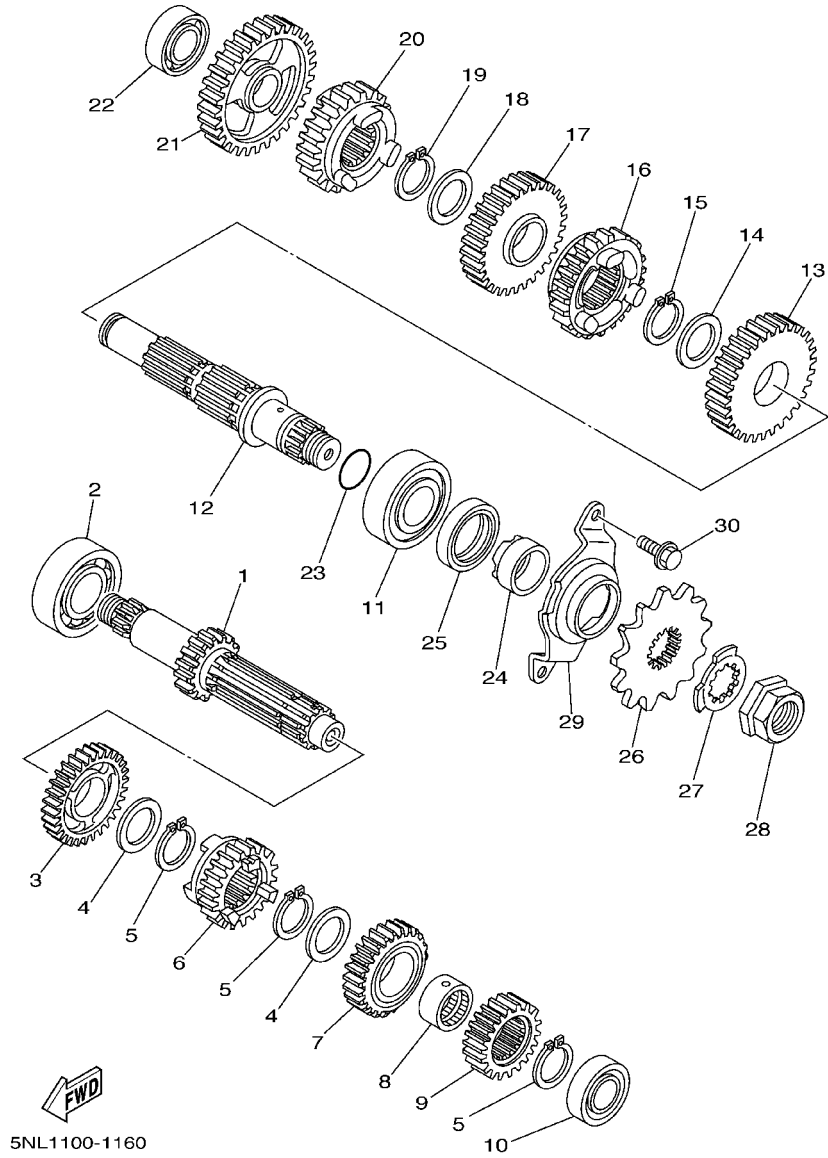

FIG. 16 TRANSMISSION



REF. NO.	PART NO.	DESCRIPTION	5SG1	5SG2	5SG3	5SG4	REMARKS
1	5NL-17411-10	AXLE,MAIN (14T)	1	1	1	1	
2	93306-20447	BEARING	1	1	1	1	
3	5NL-17151-00	GEAR, 5TH PINION (24T)	1	1	1	1	
4	90209-20008	WASHER	2	2	2	2	
5	93410-22039	CIRCLIP	3	3	3	3	
6	5NL-17131-00	GEAR, 3RD PINION (20T)	1	1	1	1	
7	5NL-17141-00	GEAR, 4TH PINION (22T)	1	1	1	1	
8	90387-20006	COLLAR	1	1	1	1	
9	5NL-17121-00	GEAR, 2ND PINION (16T)	1	1	1	1	
10	93306-00320	BEARING	1	1	1	1	
11	93306-27208	BEARING	1	1	1	1	
12	5NL-17421-00	AXLE, DRIVE	1	1	1	1	
13	5NL-17221-00	GEAR, 2ND WHEEL (28T)	1	1	1	1	
14	90209-23012	WASHER	1	1	1	1	
15	93410-26067	CIRCLIP	1	1	1	1	
16	5NL-17241-00	GEAR, 4TH WHEEL (27T)	1	1	1	1	
17	5NL-17231-00	GEAR, 3RD WHEEL (29T)	1	1	1	1	
18	90209-20008	WASHER	1	1	1	1	
19	93410-22039	CIRCLIP	1	1	1	1	
20	5NL-17251-00	GEAR, 5TH WHEEL (25T)	1	1	1	1	
21	5NL-17211-10	GEAR, 1ST WHEEL (30T)	1	1	1	1	
22	93306-00317	BEARING	1	1	1	1	
23	93210-196A4	O-RING	1	1	1	1	
24	90387-22001	COLLAR	1	1	1	1	
25	93102-28008	OIL SEAL	1	1	1	1	
26	9383B-13218	SPROCKET, DRIVE (13T)	1	1	1	1	
27	90215-20003	WASHER, LOCK	1	1	1	1	

FIG. 16 TRANSMISSION



REF. NO.	PART NO.	DESCRIPTION	5SG1	5SG2	5SG3	5SG4	REMARKS
28	90179-18001	NUT	1	1	1	1	
29	5NL-17471-00	PLATE, COVER	1	1	1	1	
30	90105-06553	BOLT, FLANGE	2	2	2	2	

FIG. 17 SHIFT CAM. FORK

REF. NO.	PART NO.	DESCRIPTION	SSG1	SSG2	SSG3	SSG4	REMARKS
1	5NL-18541-00	CAM, SHIFT	1	1	1	1	
2	93306-90501	BEARING	1	1	1	1	
3	90501-06022	SPRING, COMPRESSION	1	1	1	1	
4	4BA-18542-00	POINT, NEUTRAL	1	1	1	1	
5	5NL-18501-10	FORK, SHIFT 1	1	1	1	1	
6	5NL-18502-10	FORK, SHIFT 2	1	1	1	1	
7	5NL-18503-10	FORK, SHIFT 3	1	1	1	1	
8	3XK-18140-00	STOPPER LEVER ASSY	1	1	1	1	
9	90508-26561	SPRING, TORSION	1	1	1	1	
10	90109-063F8	BOLT	1	1	1	1	

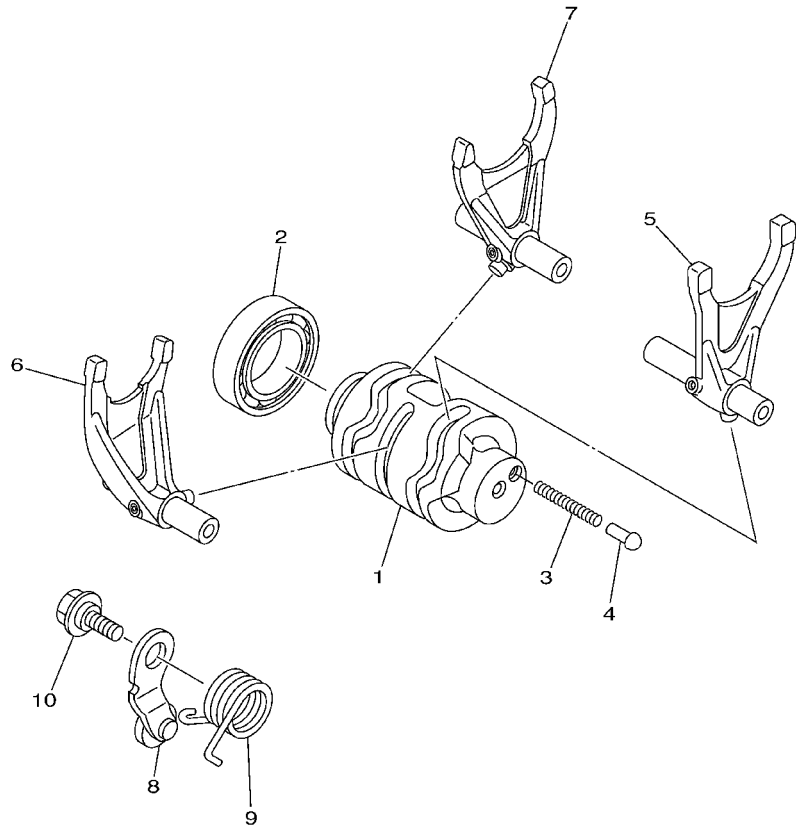

5NL1100-1170

FIG. 18 SHIFT SHAFT

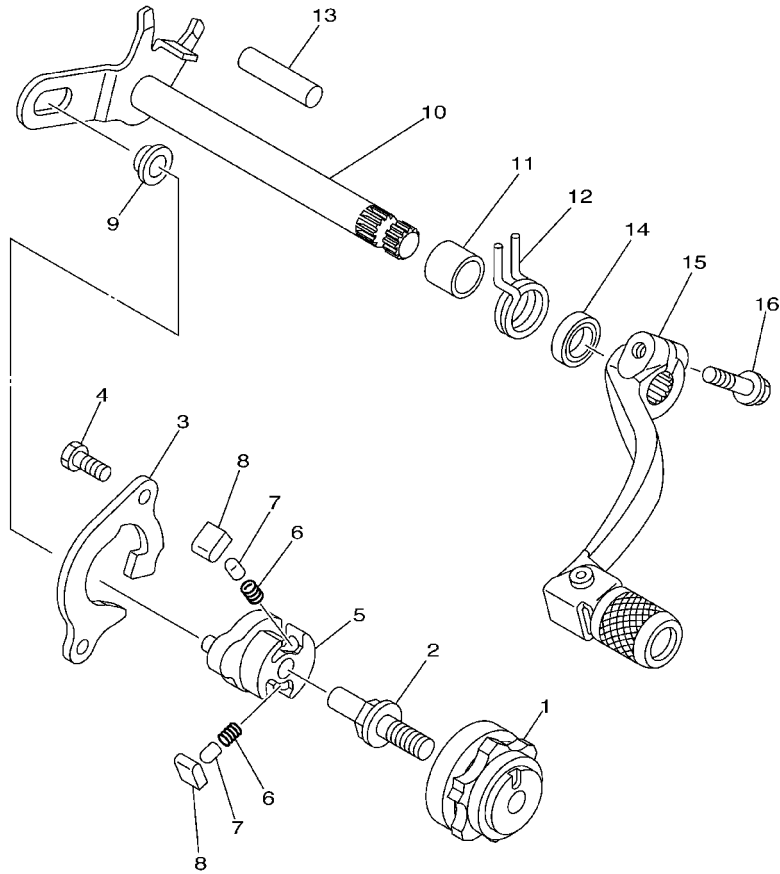

5NL1100-1180

REF. NO.	PART NO.	DESCRIPTION	5SG1	5SG2	5SG3	5SG4	REMARKS
1	4EW-18185-00	SEGMENT	1	1	1	1	
2	3XJ-18173-00	PIN, SHIFT	1	1	1	1	
3	5BE-18172-00	GUIDE, SHIFT	1	1	1	1	
4	90101-06664	BOLT	2	2	2	2	
5	5LP-18122-00	LEVER, SHIFT 2	1	1	1	1	
6	90501-052G5	SPRING, COMPRESSION	2	2	2	2	
7	3XJ-18184-00	PIN, PAWL	2	2	2	2	
8	3XJ-18182-00	PAWL, SHIFTER	2	2	2	2	
9	3XJ-18178-00	ROLLER, SHIFT LEVER	1	1	1	1	
10	5NL-18101-00	SHIFT SHAFT ASSY	1	1	1	1	
11	90387-124F4	COLLAR	1	1	1	1	
12	90508-291A8	SPRING, TORSION	1	1	1	1	
13	93608-33002	PIN, DOWEL	1	1	1	1	
14	93102-12224	OIL SEAL	1	1	1	1	
15	5NL-18110-00	SHIFT PEDAL ASSY	1	1	1	1	
16	95027-06020	BOLT, FLANGE	1	1	1	1	

FIG. 19 FRAME

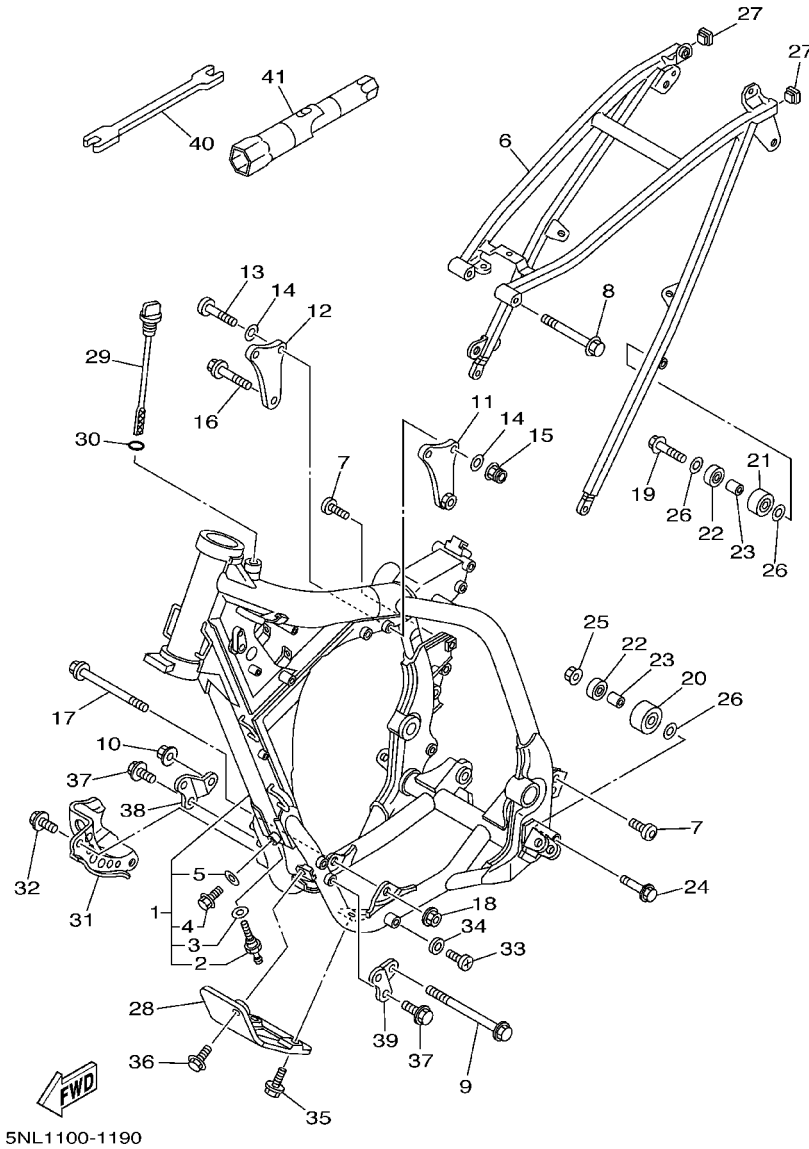

REF. NO.	PART NO.	DESCRIPTION	5SG1	5SG2	5SG3	5SG4	REMARKS
1	5SG-21101-00	FRONT FRAME COMP.	1	1	1	1	
2	5BE-21756-00	.NET, FILTER	1	1	1	1	
3	90430-18130	.GASKET	1	1	1	1	
4	95827-08012	.BOLT, FLANGE	1	1	1	1	
5	90430-08119	.GASKET	1	1	1	1	
6	5SF-21190-00	REAR FRAME COMP.	1	1	1	1	
7	90110-08096	BOLT, HEXAGON SOCKET HEAD	2	2	2	2	
8	90105-08099	BOLT, FLANGE	1	1	1	1	
9	95817-10130	BOLT, FLANGE	1	1	1	1	
10	90185-10002	NUT, SELF-LOCKING	1	1	1	1	
11	5NL-21425-00	BRACKET, REAR UPPER 1	1	1	1	1	
12	5NL-21425-10	BRACKET, REAR UPPER 1	1	1	1	1	
13	92017-08055	BOLT, BUTTON HEAD	2	2	2	2	
14	90201-086P8	WASHER, PLATE	4	4	4	4	
15	90185-08169	NUT, SELF-LOCKING	2	2	2	2	
16	95817-10050	BOLT, FLANGE	1	1	1	1	
17	90105-10733	BOLT, FLANGE	1	1	1	1	
18	90185-10002	NUT, SELF-LOCKING	1	1	1	1	
19	95027-08040	BOLT, FLANGE	1	1	1	1	
20	3JD-22178-10	TENSIONER	1	1	1	1	
21	4EW-22178-00	TENSIONER	1	1	1	1	
22	93300-60804	BEARING	2	2	2	2	
23	90387-086N4	COLLAR	2	2	2	2	
24	95027-08065	BOLT, FLANGE	1	1	1	1	
25	95707-08500	NUT, FLANGE	1	1	1	1	
26	90201-086P8	WASHER, PLATE	3	3	3	3	
27	90338-16148	PLUG	2	2	2	2	

FIG. 19 FRAME

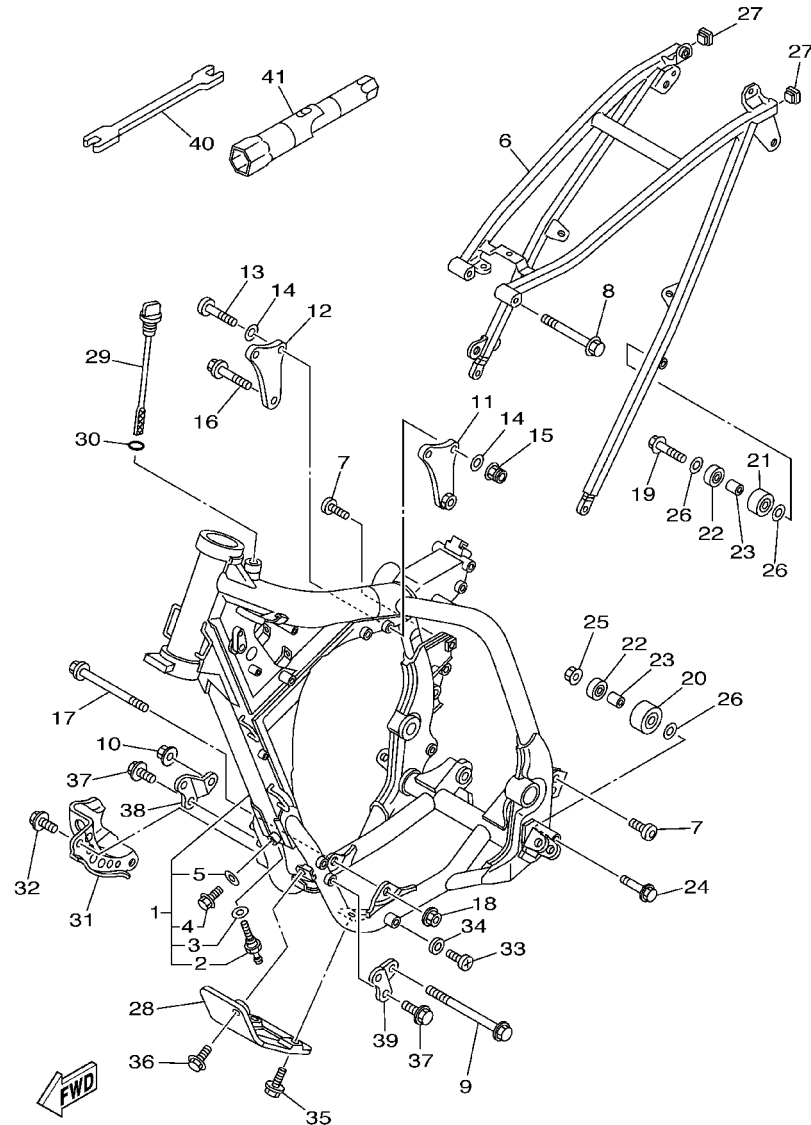

5NL1100-1190

REF. NO.	PART NO.	DESCRIPTION	SSG1	SSG2	SSG3	SSG4	REMARKS
28	5NL-21471-00	PROTECTOR, ENGINE	1	1	1	1	
29	5NL-15362-00	PLUG, OIL LEVEL	1	1	1	1	
30	93210-19123	O-RING	1	1	1	1	
31	5NL-2147A-00	GUARD, ENGINE 1	1	1	1	1	
32	95027-08012	BOLT, FLANGE	2	2	2	2	
33	90157-08028	SCREW, PAN HEAD	1	1	1	1	
34	90202-08204	WASHER, PLATE	1	1	1	1	
35	95027-06012	BOLT, FLANGE	2	2	2	2	
36	90119-06001	BOLT, WITH WASHER	1	1	1	1	
37	95817-08016	BOLT, FLANGE	4	4	4	4	
*38	5NL-21417-00	BRACKET, FRONT LOWER 1	1	1	1	1	
*39	5NL-21417-10	BRACKET, FRONT LOWER 1	1	1	1	1	
40	5ET-28166-00	WRENCH, HEXAGON	1	1	1	1	
41	5BE-2814F-00	BOX, SPARK PLUG	1	1	1	1	

FIG. 20 FENDER

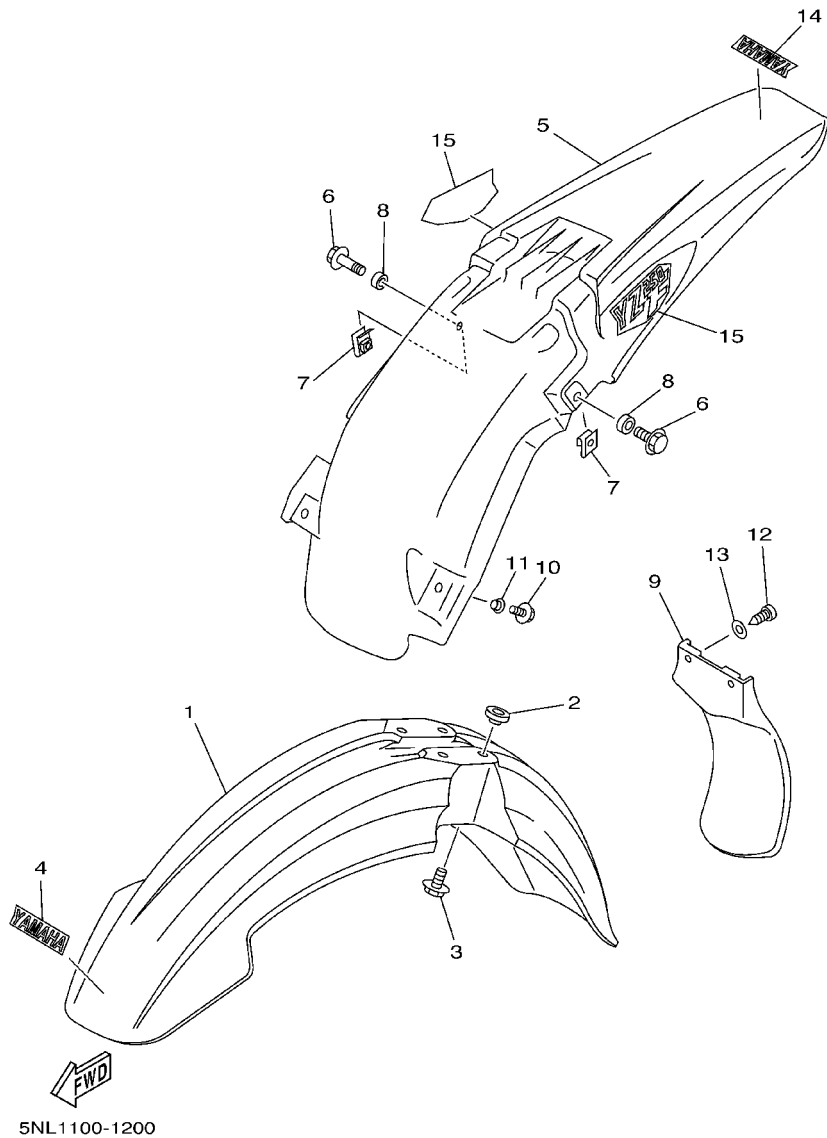

REF. NO.	PART NO.	DESCRIPTION	5SG1	5SG2	5SG3	5SG4	REMARKS
1	5HD-21511-00	FENDER, FRONT	1	1	1	1	
2	3JD-21748-00	COLLAR	4	4	4	4	
3	90119-06096	BOLT, WITH WASHER	4	4	4	4	
4	4ES-2153E-01	EMBLEM, YAMAHA	1	1	1	1	
5	5BE-21611-10	FENDER, REAR	1	1	1	1	
6	90105-06154	BOLT, FLANGE	2	2	2	2	
7	90183-06023	NUT, SPRING	2	2	2	2	
8	90387-0701A	COLLAR	2	2	2	2	
9	5BE-21642-00	GUARD, FLAP	1	1	1	1	
10	90105-06690	BOLT, FLANGE	2	2	2	2	
11	90387-06009	COLLAR	2	2	2	2	
12	97707-60016	SCREW, TAPPING	2	2	2	2	
13	90201-06557	WASHER, PLATE	2	2	2	2	
14	4ES-2153E-01	EMBLEM, YAMAHA	1	1	1	1	EXCEPT FOR CAN
15	5SG-2163G-00	EMBLEM 1	2	2	2	2	

FIG. 21 SIDE COVER

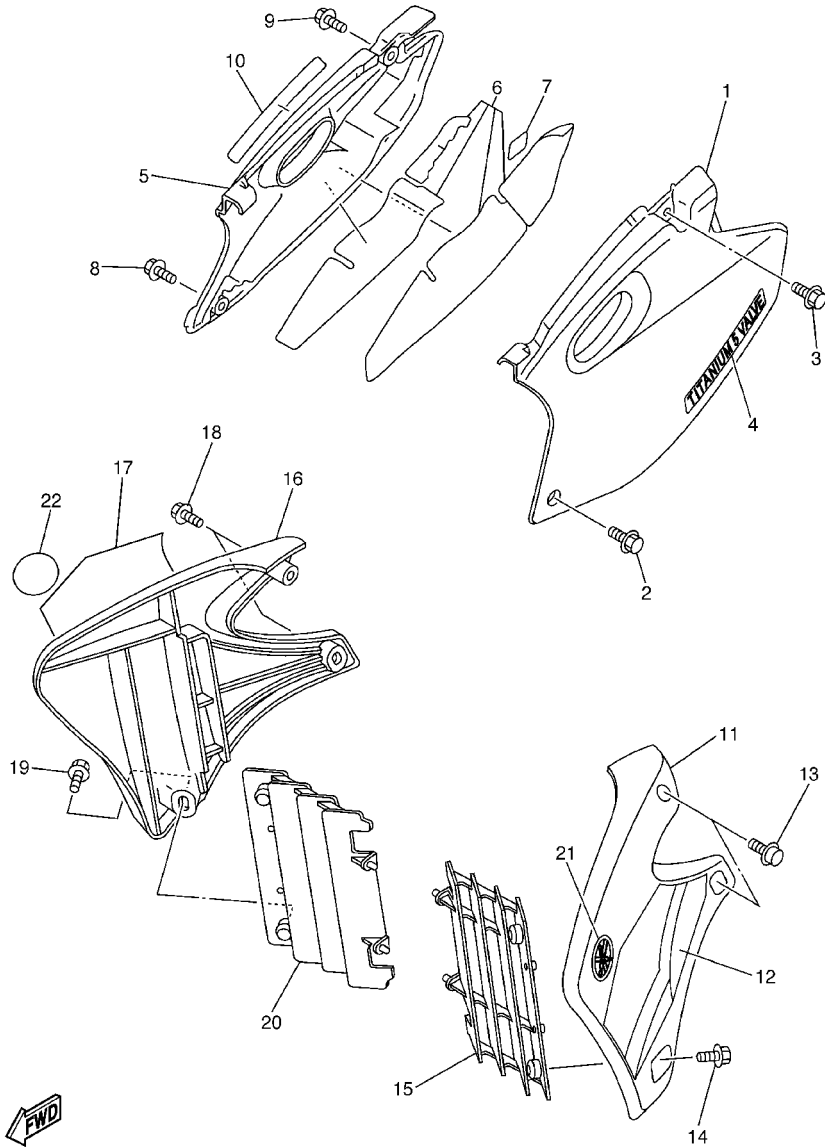

FWD
5SG1100-2210

REF. NO.	PART NO.	DESCRIPTION	5SG1	5SG2	5SG3	5SG4	REMARKS
1	5BE-21711-00	COVER, SIDE 1	1	1	1	1	
2	95827-06016	BOLT, FLANGE	1	1	1	1	
3	90119-08238	BOLT, WITH WASHER	1	1	1	1	
4	5JG-21781-50	EMBLEM 1	1	1	1	1	
5	5BE-21721-00	COVER, SIDE 2	1	1	1	1	
6	5SF-2174A-00	INSULATOR, SIDE COVER	1	1	1	1	
7	3FY-21575-01	SEAL 1	1	1	1	1	
8	95827-06016	BOLT, FLANGE	1	1	1	1	
9	90119-08238	BOLT, WITH WASHER	1	1	1	1	
10	5JG-21781-50	EMBLEM 1	1	1	1	1	
11	5NL-21731-00	COVER, SIDE 3	1	1	1	1	
12	5SF-2173E-01	GRAPHIC 1	1	1	1	1	
13	90159-06182	SCREW, WITH WASHER	2	2	2	2	
14	90159-06078	SCREW, WITH WASHER	1	1	1	1	
15	5NL-2172A-10	PANEL 1	1	1	1	1	
16	5NL-21741-00	COVER, SIDE 4	1	1	1	1	
17	5SF-2173F-01	GRAPHIC 2	1	1	1	1	
18	90159-06182	SCREW, WITH WASHER	2	2	2	2	
19	90159-06078	SCREW, WITH WASHER	1	1	1	1	
20	5NL-2172A-10	PANEL 1	1	1	1	1	
21	5MV-2175C-00	TUNING FORK MARK	1	1	1	1	
22	5MV-2175C-00	TUNING FORK MARK	1	1	1	1	

FIG. 22 REAR ARM

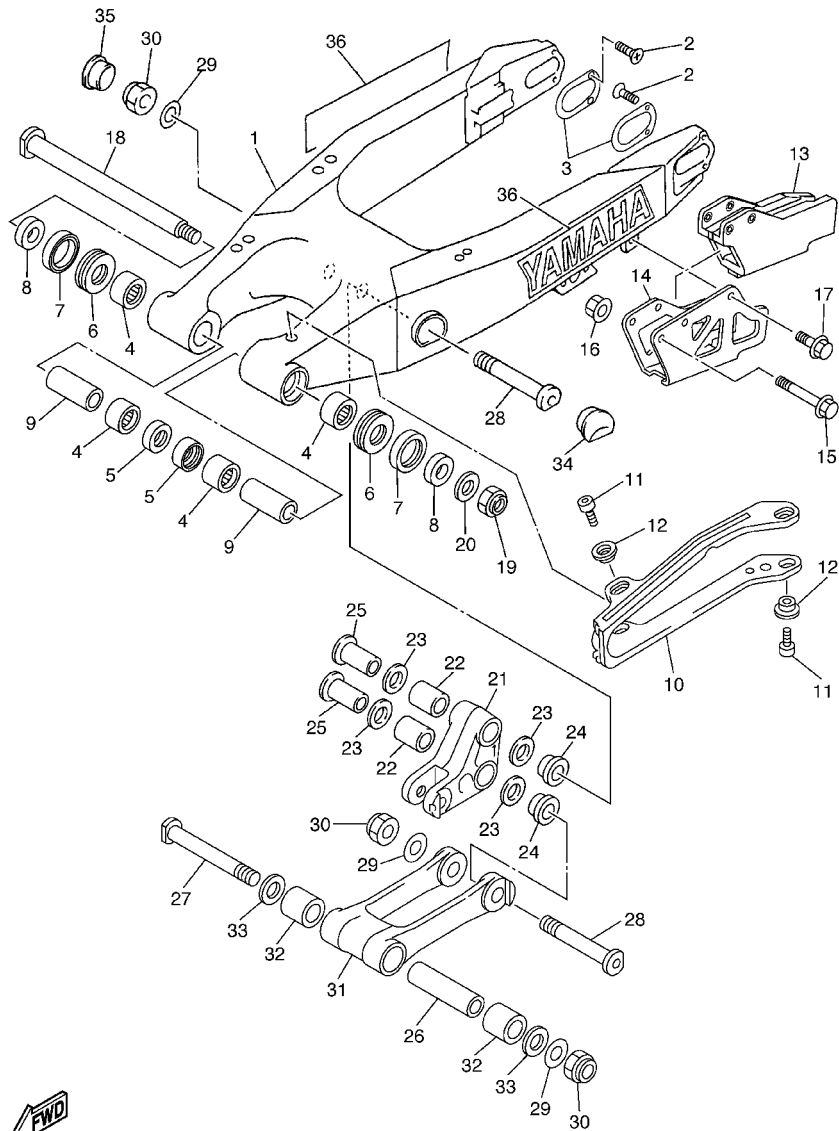

 5SG1100-2220

REF. NO.	PART NO.	DESCRIPTION	5SG1	5SG2	5SG3	5SG4	REMARKS
1	5NY-22110-00	REAR ARM COMP.	1	1	1	1	
2	90151-04048	SCREW, COUNTERSUNK	4	4	4	4	
3	5NY-22355-00	PATCH	2	2	2	2	
4	93317-22262	BEARING	4	4	4	4	
5	93106-22019	OIL SEAL (DC 22-28-8)	2	2	2	2	
6	93342-22217	BEARING	2	2	2	2	
7	93109-28043	OIL SEAL	2	2	2	2	
8	90387-18005	COLLAR	2	2	2	2	
9	90387-18004	COLLAR	2	2	2	2	
10	5MV-22151-00	SEAL, GUARD	1	1	1	1	
11	91317-05008	BOLT	4	4	4	4	
12	5JG-22156-00	WASHER, PLATE	4	4	4	4	
13	4XM-22199-00	SUPPORT, CHAIN	1	1	1	1	
14	4XM-22128-00	COVER, THRUST 1	1	1	1	1	
15	95027-06050	BOLT, FLANGE	2	2	2	2	
16	90179-06568	NUT	2	2	2	2	
17	95027-06010	BOLT, FLANGE	1	1	1	1	
18	5NY-22141-00	SHAFT, PIVOT	1	1	1	1	
19	90185-16127	NUT, SELF-LOCKING	1	1	1	1	
20	90201-160F6	WASHER, PLATE	1	1	1	1	
21	5NY-2217A-00	ARM, RELAY	1	1	1	1	
22	93315-32056	BEARING	2	2	2	2	
23	93109-20076	OIL SEAL	4	4	4	4	
24	90387-16005	COLLAR	2	2	2	2	
25	90387-16007	COLLAR	2	2	2	2	
26	90387-167Y9	COLLAR	1	1	1	1	
27	5NY-22121-00	SHAFT 1	1	1	1	1	

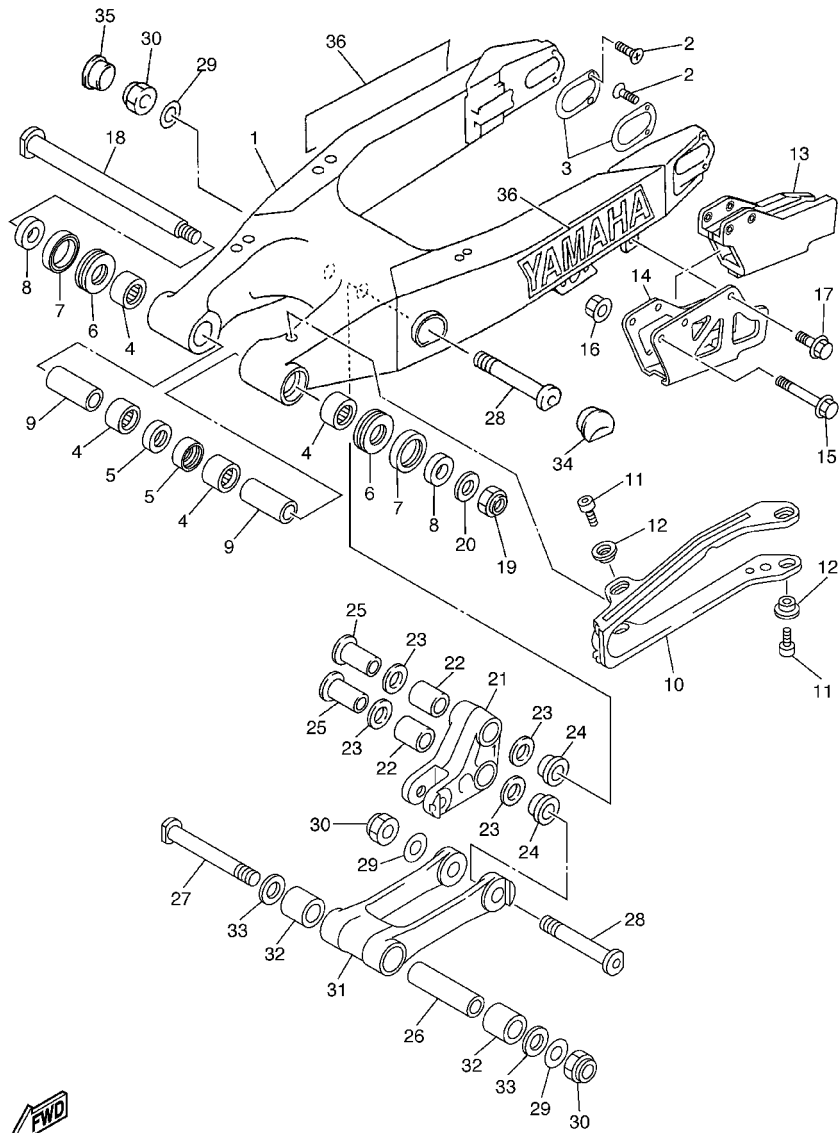
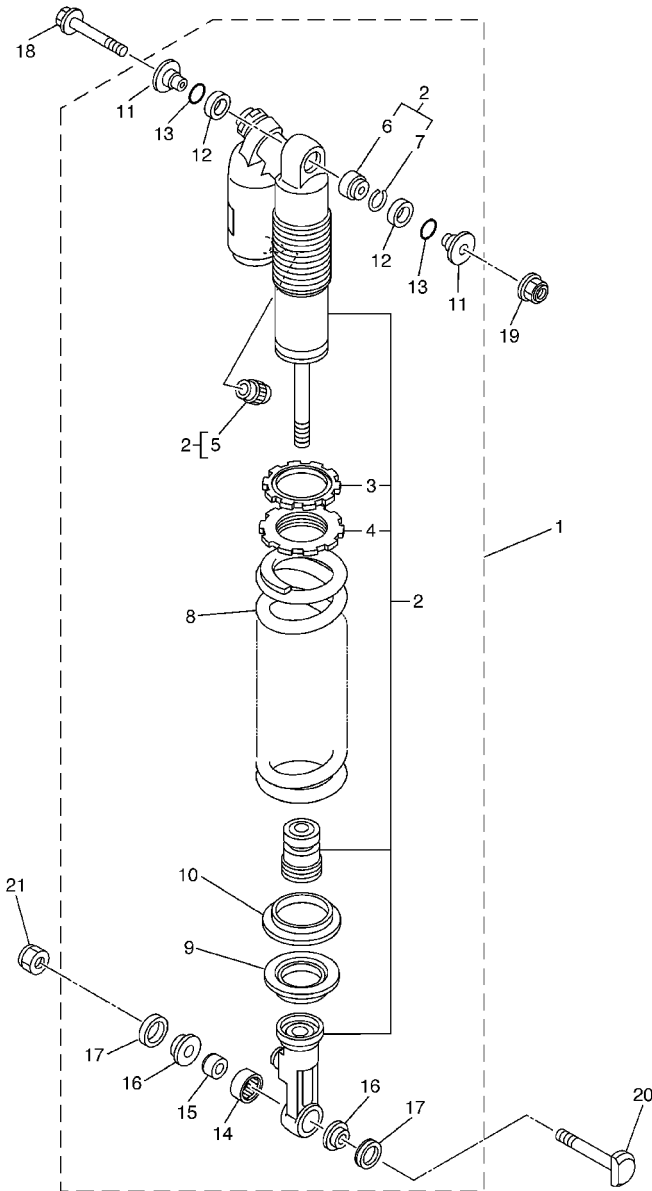

FIG. 22 REAR ARM

REF. NO.	PART NO.	DESCRIPTION	5SG1	5SG2	5SG3	5SG4	REMARKS
28	5NY-22122-00	SHAFT 2	2	2	2	2	
29	90201-14740	WASHER, PLATE	3	3	3	3	
30	90185-14007	NUT, SELF-LOCKING	3	3	3	3	
31	5NY-2217F-00	ROD, CONNECTING 1	1	1	1	1	
32	93315-32053	BEARING	2	2	2	2	
33	93109-20076	OIL SEAL	2	2	2	2	
34	5NY-2135F-00	COVER	1	1	1	1	
35	5HD-2135F-00	COVER	1	1	1	1	
36	99244-00200	EMBLEM, YAMAHA	2	2	2	2	

 5SG1100-2220

FIG. 23 REAR SUSPENSION



5SG1100-2230

REF. NO.	PART NO.	DESCRIPTION	5SG1	5SG2	5SG3	5SG4	REMARKS
1	5SG-22210-00	SHOCK ABSORBER ASSY, REAR	1				
	5SG-22210-10	SHOCK ABSORBER ASSY, REAR		1			
	5SG-22210-20	SHOCK ABSORBER ASSY, REAR			1		
	5SG-22210-30	SHOCK ABSORBER ASSY, REAR				1	UR FOR CAN
	5SG-22210-40	SHOCK ABSORBER ASSY, REAR				1	UR
2	5SG-22201-00	.DAMPER SUB ASSY	1				
	5SG-22201-10	.DAMPER SUB ASSY		1			
	5SG-22201-20	.DAMPER SUB ASSY			1		
	5SG-22201-30	.DAMPER SUB ASSY				1	UR FOR CAN
	5SG-22201-40	.DAMPER SUB ASSY				1	UR
3	3SP-22234-00	..GUIDE, SPRING 3	1	1	1	1	
4	3SP-22213-00	..SEAT, SPRING UPPER	1	1	1	1	
5	509-23184-L0	..CAP, AIR VALVE	1	1	1	1	
6	4JX-22226-00	..BUSH, SHOCK ABSORBER LOWER	1	1	1	1	
7	5DH-23183-00	..CIRCLIP	1	1	1	1	
8	5DH-22212-20	..SPRING (K=4.8)	1		1	1	
	5ET-22212-10	..SPRING (K=APPROX.5.0)		1			
9	5DH-22214-00	..GUIDE, SPRING 1	1	1	1	1	
10	5MV-22224-00	..GUIDE, SPRING 2	1	1	1	1	
11	5DH-22253-00	..COLLAR, DISTANCE	2	2	2	2	
12	3JE-22475-00	..SEAL, DUST	2	2	2	2	
13	4EW-22474-00	..SEAL, RING	2	2	2	2	
14	5MV-22176-00	..BEARING	1	1	1	1	
15	5MV-22184-00	..BUSH	1	1	1	1	
16	5MV-22253-00	..COLLAR, DISTANCE	2	2	2	2	
17	5NY-22475-00	..SEAL, DUST	2	2	2	2	
18	90105-10323	BOLT, FLANGE	1	1	1	1	

D6

FIG. 23 REAR SUSPENSION

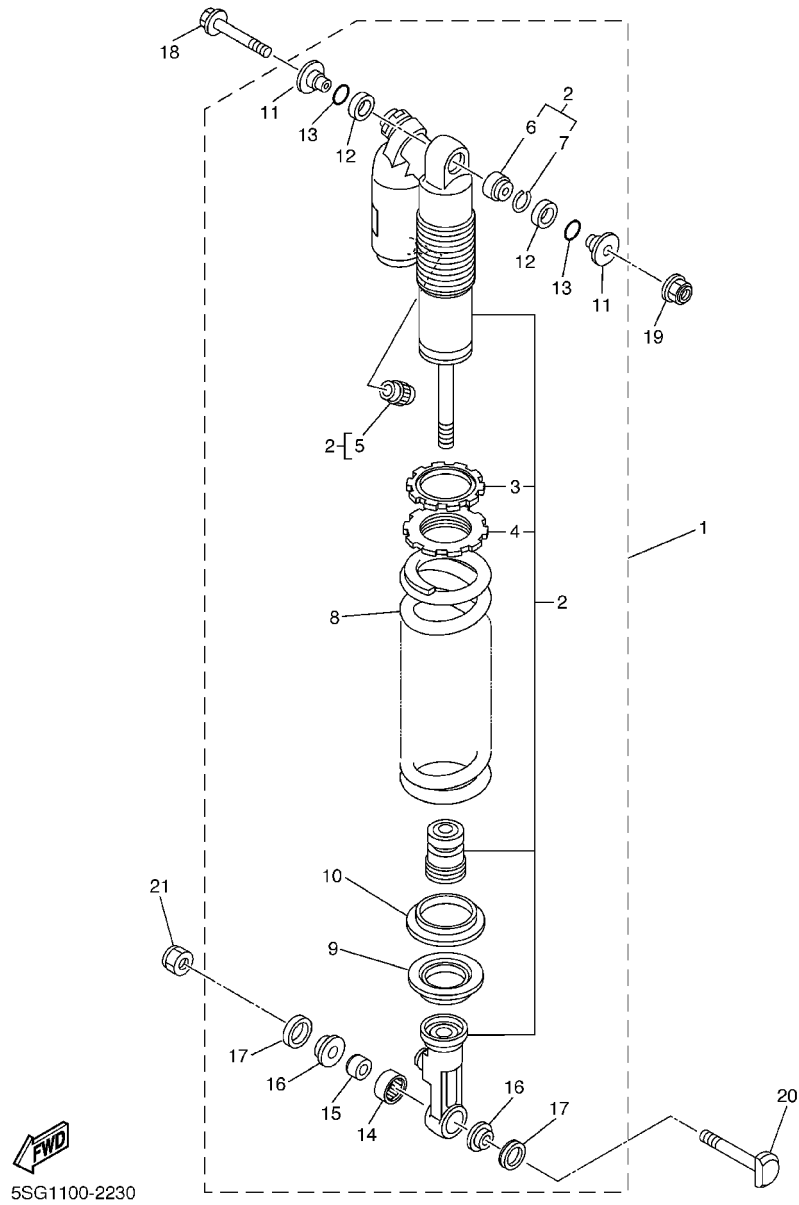

REF. NO.	PART NO.	DESCRIPTION	5SG1	5SG2	5SG3	5SG4	REMARKS
19	95607-10200	NUT, U FLANGE	1	1	1	1	
20	5NY-22241-00	BOLT 1	1	1	1	1	
21	90185-10060	NUT, SELF-LOCKING	1	1	1	1	

FIG. 24 STEERING

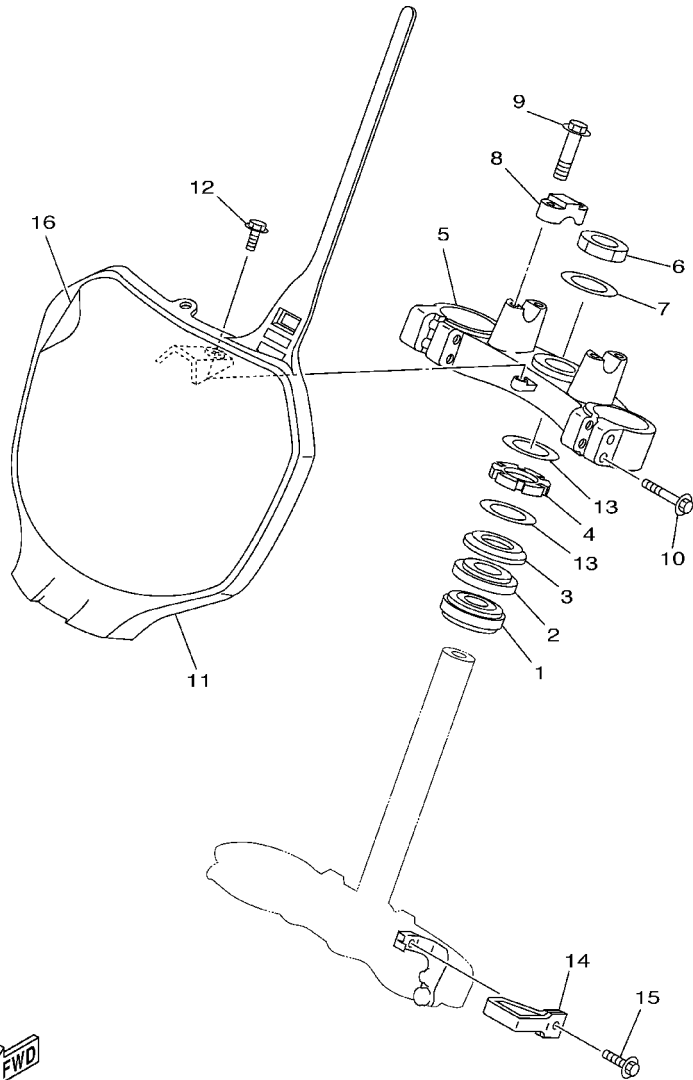

REF. NO.	PART NO.	DESCRIPTION	5SG1	5SG2	5SG3	5SG4	REMARKS
1	93332-00081	BEARING	1	1	1	1	
2	93332-00068	BEARING	1	1	1	1	
3	4EW-23416-00	COVER, BALL RACE 2	1	1	1	1	
4	90179-28650	NUT	1	1	1	1	
5	5NL-23435-00	CROWN, HANDLE	1	1	1	1	
6	90170-24373	NUT	1	1	1	1	
7	90201-247L2	WASHER, PLATE	1	1	1	1	
8	3SP-23441-00	HOLDER, HANDLE UPPER	2	2	2	2	
9	95027-08035	BOLT, FLANGE	4	4	4	4	
10	95027-08040	BOLT, FLANGE	4	4	4	4	
11	5HD-23485-10	PLATE, NUMBER	1	1	1	1	
12	90119-06225	BOLT, WITH WASHER	1	1	1	1	
13	90201-286K9	WASHER, PLATE	2	2	2	2	
14	4DA-23389-00	GUIDE, CABLE	1	1	1	1	
15	90119-05071	BOLT, WITH WASHER	1	1	1	1	
16	5HD-2339E-00	GRAPHIC 1	1	1	1	1	

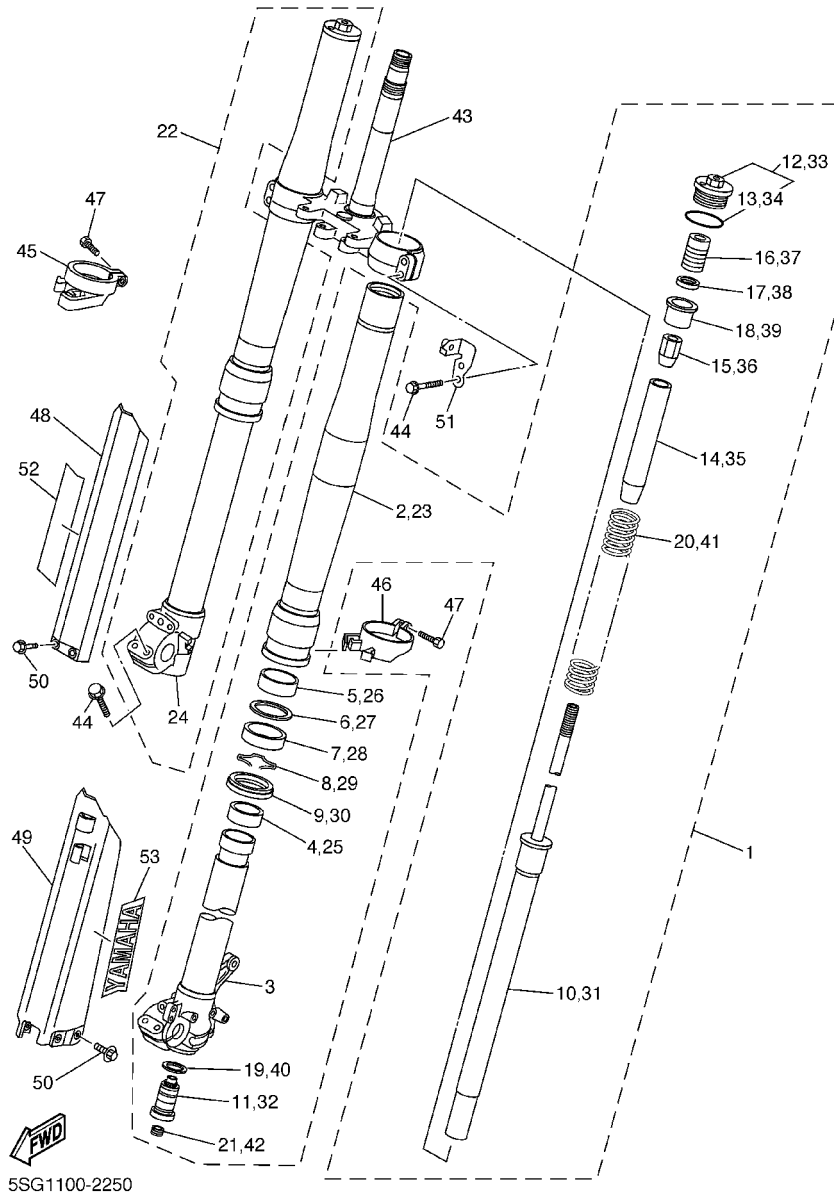

5NL1100-1240

FIG. 25 FRONT FORK

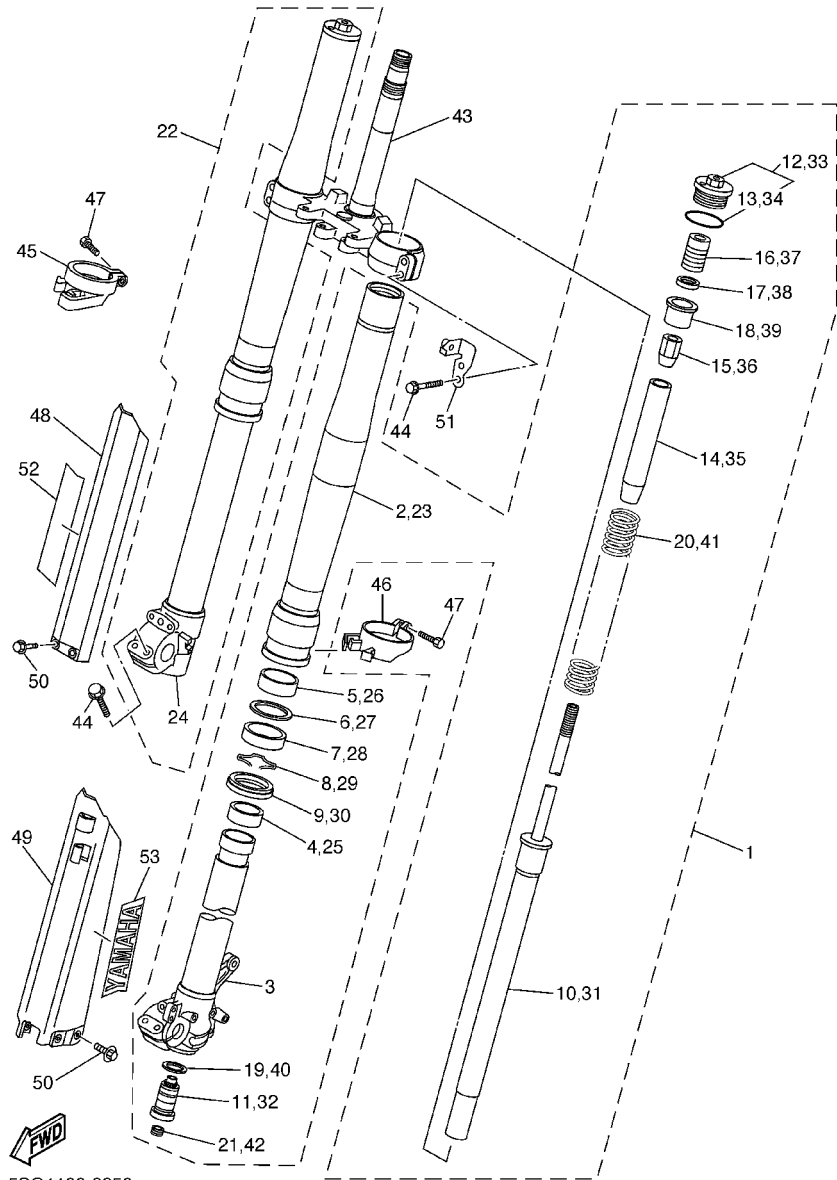

REF. NO.	PART NO.	DESCRIPTION	5SG1	5SG2	5SG3	5SG4	REMARKS
1	5SG-23102-00	FRONT FORK ASSY (L.H)	1		1	1	
	5SG-23102-10	FRONT FORK ASSY (L.H)		1			
2	5HD-23136-L0	.TUBE, OUTER (RIGHT)	1	1	1	1	
3	5DH-23120-L0	.INNER TUBE COMP.2	1	1	1	1	
4	5ET-23171-L0	.PISTON, FRONT FORK	1	1	1	1	
5	5ET-23125-L0	.METAL, SLIDE 1	1	1	1	1	
6	4SS-23146-L0	.WASHER, OIL SEAL	1	1	1	1	
7	5ET-23145-L0	.OIL SEAL	1	1	1	1	
8	4SS-23153-L0	.RING, SNAP	1	1	1	1	
9	5HD-23144-L0	.SEAL, DUST	1	1	1	1	
10	5NY-23170-L0	.CYLINDER COMP., FRONT FORK	1	1	1	1	
11	5SG-2316A-00	.VALVE COMP.	1		1	1	
	5SG-2316A-10	.VALVE COMP.		1			
12	5NY-23111-L0	.BOLT, CAP	1	1	1	1	
13	93210-42263	..O-RING	1	1	1	1	
14	5DH-23142-L0	.SEAT, SPRING UPPER	1	1	1	1	
15	5HD-23393-L0	.NUT, SPECIAL	1	1	1	1	
16	5MV-23195-L0	.RUBBER	1	1	1	1	
17	5DH-23149-L0	.WASHER, SPRING UPPER	1	1	1	1	
18	5DH-23118-L0	.SPACER	1	1	1	1	
19	4SS-23158-L0	.GASKET	1	1	1	1	
20	5NL-23141-00	.SPRING,FRONT FORK (K=0.44)	1		1	1	
	5CU-23141-L0	.SPRING (K=APPROX.0.43)		1			
21	3JD-2312G-L0	.PLUG	1	1	1	1	
22	5SG-23103-00	FRONT FORK ASSY (R.H)	1		1	1	
	5SG-23103-10	FRONT FORK ASSY (R.H)		1			
23	5HD-23136-L0	.TUBE, OUTER (RIGHT)	1	1	1	1	

FIG. 25 FRONT FORK



5SG1100-2250

REF. NO.	PART NO.	DESCRIPTION	5SG1	5SG2	5SG3	5SG4	REMARKS
24	5BF-23110-L0	.INNER TUBE COMP.1	1	1	1	1	
25	5ET-23171-L0	.PISTON, FRONT FORK	1	1	1	1	
26	5ET-23125-L0	.METAL, SLIDE 1	1	1	1	1	
27	4SS-23146-L0	.WASHER, OIL SEAL	1	1	1	1	
28	5ET-23145-L0	.OIL SEAL	1	1	1	1	
29	4SS-23153-L0	.RING, SNAP	1	1	1	1	
30	5HD-23144-L0	.SEAL, DUST	1	1	1	1	
31	5NY-23170-L0	.CYLINDER COMP., FRONT FORK	1	1	1	1	
32	5SG-2316A-00	.VALVE COMP.	1		1	1	
	5SG-2316A-10	.VALVE COMP.			1		
33	5NY-23111-L0	.BOLT, CAP	1	1	1	1	
34	93210-42263	..O-RING	1	1	1	1	
35	5DH-23142-L0	.SEAT, SPRING UPPER	1	1	1	1	
36	5HD-23393-L0	.NUT, SPECIAL	1	1	1	1	
37	5MV-23195-L0	.RUBBER	1	1	1	1	
38	5DH-23149-L0	.WASHER, SPRING UPPER	1	1	1	1	
39	5DH-23118-L0	.SPACER	1	1	1	1	
40	4SS-23158-L0	.GASKET	1	1	1	1	
41	5NL-23141-00	.SPRING,FRONT FORK (K=0.44)	1		1	1	
	5CU-23141-L0	.SPRING (K=APPROX.0.43)			1		
42	3JD-2312G-L0	.PLUG	1	1	1	1	
43	5SG-23340-00	UNDER BRACKET COMP.	1	1	1	1	
44	5NY-23346-L0	BOLT 1	8	8	8	8	
45	4SS-2314G-L0	PROTECTOR GUIDE COMP., 2	1	1	1	1	
46	5DH-2314F-L0	PROTECTOR GUIDE COMP., 1	1	1	1	1	
47	4SS-23346-L0	BOLT 1	2	2	2	2	
48	5DH-2314J-00	PROTECTOR COMP., 2	1	1	1	1	

FIG. 25 FRONT FORK

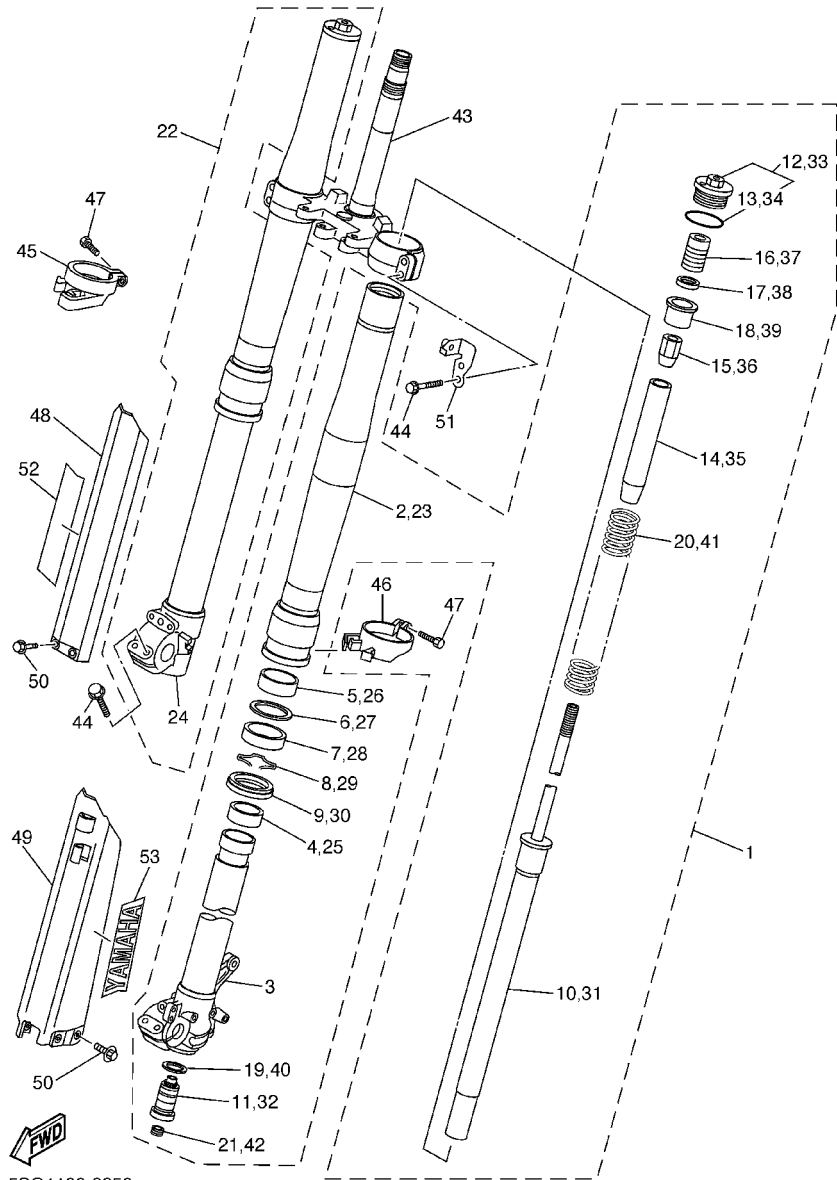

5SG1100-2250

REF. NO.	PART NO.	DESCRIPTION	5SG1	5SG2	5SG3	5SG4	REMARKS
49	5DH-2314H-00	PROTECTOR COMP., 1	1	1	1	1	
50	3SP-23356-L0	BOLT 2	6	6	6	6	
51	5HC-2331E-00	GUIDE, CABLE	1	1	1	1	
52	4XL-2153A-10	EMBLEM, YAMAHA	1	1	1	1	
53	4XL-2153A-10	EMBLEM, YAMAHA	1	1	1	1	

FIG. 26 FUEL TANK

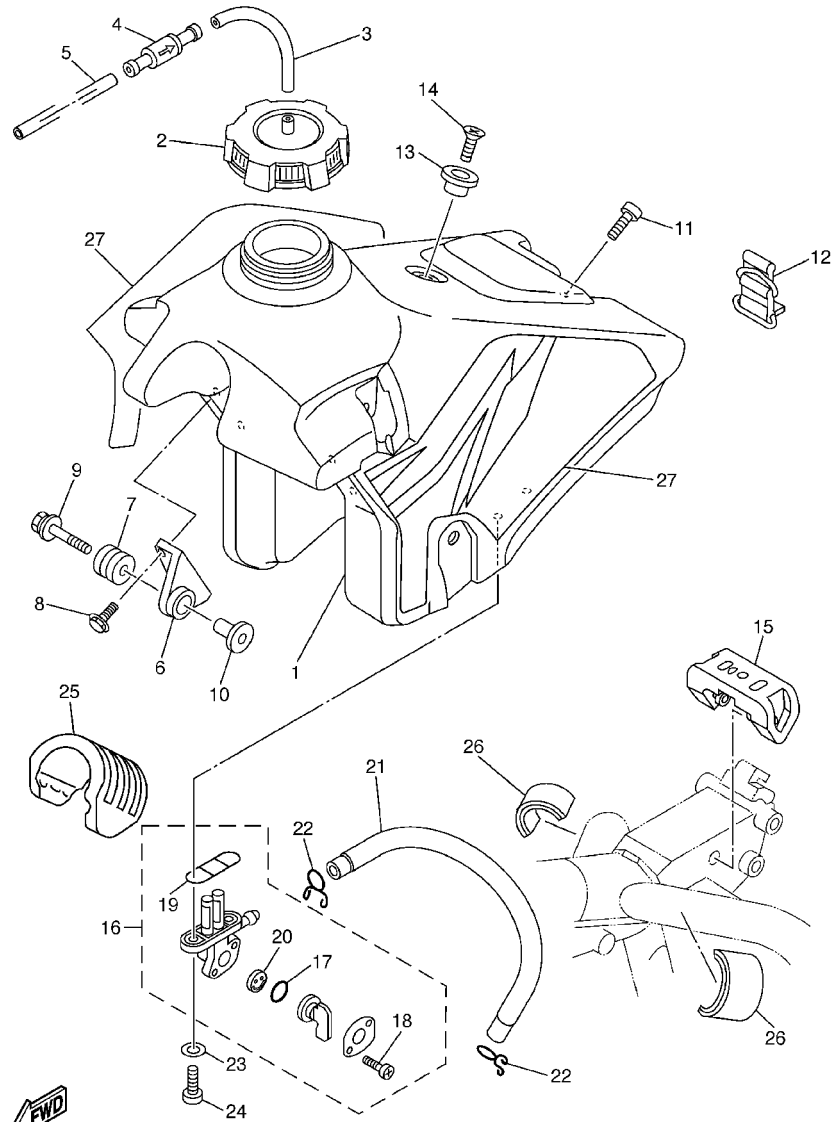

5SG1100-2260

REF. NO.	PART NO.	DESCRIPTION	5SG1	5SG2	5SG3	5SG4	REMARKS
1	5JG-24110-50	FUEL TANK COMP.	1	1	1	1	
2	5MV-24610-00	CAP ASSY	1	1	1	1	
3	90445-09220	HOSE	1	1	1	1	
4	3XJ-24380-00	PIPE JOINT ASSY	1	1	1	1	
5	90445-09104	HOSE	1	1	1	1	
6	24X-24144-00	HOLDER, DAMPER	2	2	2	2	
7	90480-18549	GROMMET	2	2	2	2	
8	95027-06016	BOLT, FLANGE	4	4	4	4	
9	90119-06214	BOLT, WITH WASHER	2	2	2	2	
10	3JD-24186-00	WASHER, SPECIAL	2	2	2	2	
11	98907-06020	SCREW, BIND	1	1	1	1	
12	5SF-24173-00	BAND, TANK FITTING 1	1	1	1	1	
13	4EW-2412F-00	BRACKET, SEAT	1	1	1	1	
14	98707-06025	SCREW, FLAT HEAD	1	1	1	1	
15	4SS-24181-00	DAMPER, LOCATING 1	1	1	1	1	
16	4DP-24500-00	FUEL COCK ASSY 1	1	1	1	1	
17	3AJ-24534-00	.SEAL, COCK	1	1	1	1	
18	97801-03008	.SCREW, PAN HEAD	2	2	2	2	
19	4X8-24512-00	.O-RING	1	1	1	1	
20	3AJ-24523-00	.VALVE PACKING	1	1	1	1	
21	90445-11002	HOSE (L195)	1	1	1	1	
22	90467-10008	CLIP	2	2	2	2	
23	90202-05193	WASHER, PLATE	2	2	2	2	
24	90149-06011	SCREW	2	2	2	2	
25	5BE-24182-00	DAMPER, LOCATING 2	1	1	1	1	
26	3V6-22358-00	SEAL 1	2	2	2	2	
27	5SF-24240-01	GRAPHIC SET	1	1	1	1	

FIG. 27 SEAT

REF. NO.	PART NO.	DESCRIPTION	SSG1	SSG2	SSG3	SSG4	REMARKS
1	5SF-24710-00	SINGLE SEAT ASSY	1	1	1	1	
2	5SF-24731-00	.COVER, SEAT	1	1	1	1	
3	5BE-24728-00	.BRACKET, SEAT	2	2	2	2	
4	97007-06012	.BOLT	4	4	4	4	
5	92907-06100	.WASHER, SPRING	4	4	4	4	

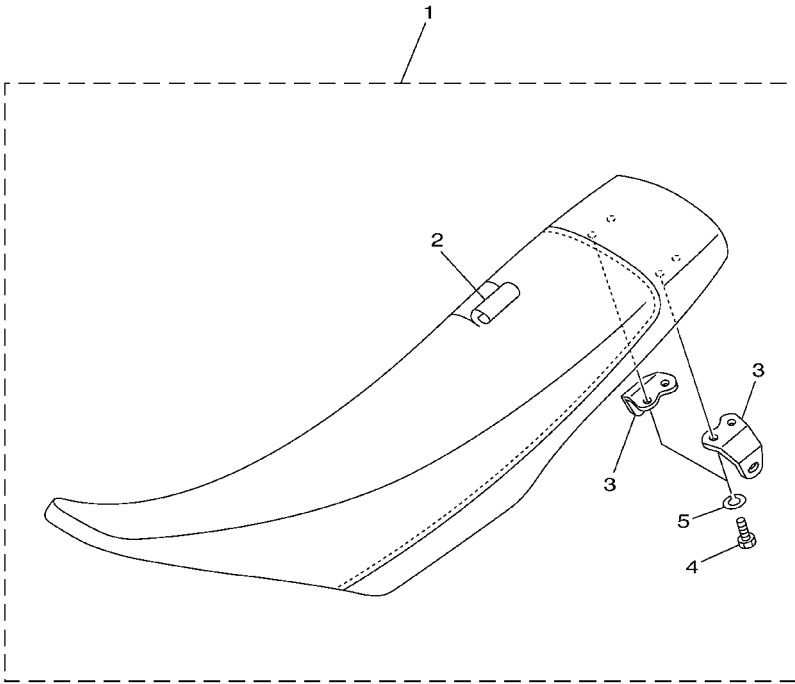

5NL1100-1270

FIG. 28 FRONT WHEEL

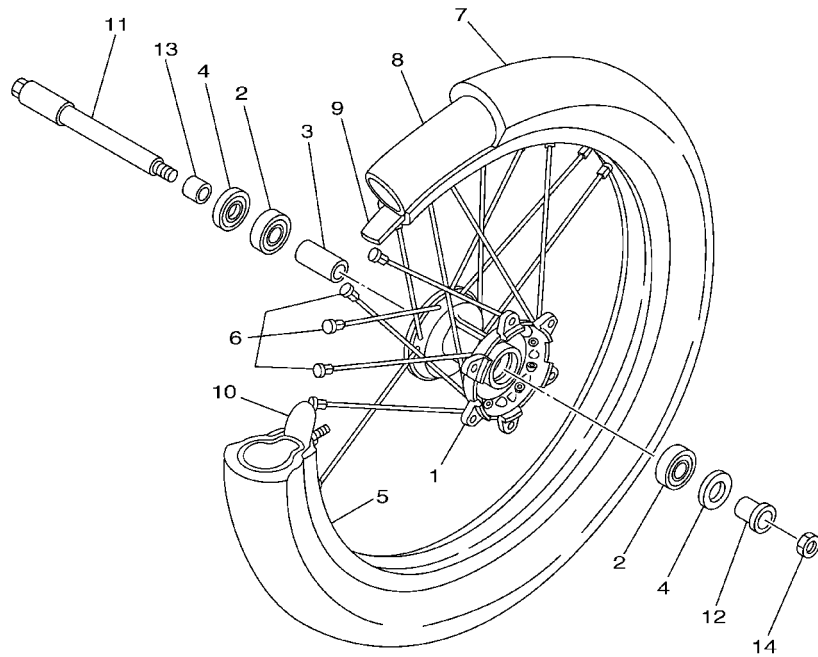

REF. NO.	PART NO.	DESCRIPTION	SSG1	SSG2	SSG3	SSG4	REMARKS
1	5NY-25111-00	HUB, FRONT	1	1	1	1	
2	93306-90403	BEARING	2	2	2	2	
3	5NY-25117-00	SPACER, BEARING	1	1	1	1	
4	93102-26468	OIL SEAL	2	2	2	2	
5	94416-21005	RIM (1.60-21)	1	1	1	1	
6	5NY-25104-00	SPOKE SET, FRONT	1	1	1	1	
7	94108-21008	TIRE (80/100-21 51M D739FA)	1			1	DUNLOP
	*	TIRE (80/100-21 MT320)		1			LM PIRELLI
	94108-2110Y	TIRE (80/100-21 51M M77)			1		BRIDGESTONE
	94108-2112Y	TIRE (80/100-21 51M D755F)		1		1	DUNLOP
8	94227-21101	TUBE (80/100-21 TR4 BTL)	1	1		1	DUNLOP
	*	TUBE (80/100-21)		1			LM PIRELLI
	94209-21229	TUBE (80/100C-21 TR4)			1		BRIDGESTONE
9	94309-21161	BAND, RIM (70-80/100-21)	1	1		1	DUNLOP
	*	BAND, RIM (80/100-21)			1		LM PIRELLI
	94330-21084	BAND, RIM (3.00-21)				1	BRIDGESTONE
10	5SF-25394-00	SPACER, BEAD	1	1	1	1	
11	5BE-25181-00	AXLE, WHEEL	1	1	1	1	
12	5NY-25183-00	COLLAR, WHEEL	1	1	1	1	
13	5NY-25186-00	COLLAR, WHEEL	1	1	1	1	
14	90179-16672	NUT	1	1	1	1	



5NL1100-1280

FIG. 29 FRONT BRAKE CALIPER

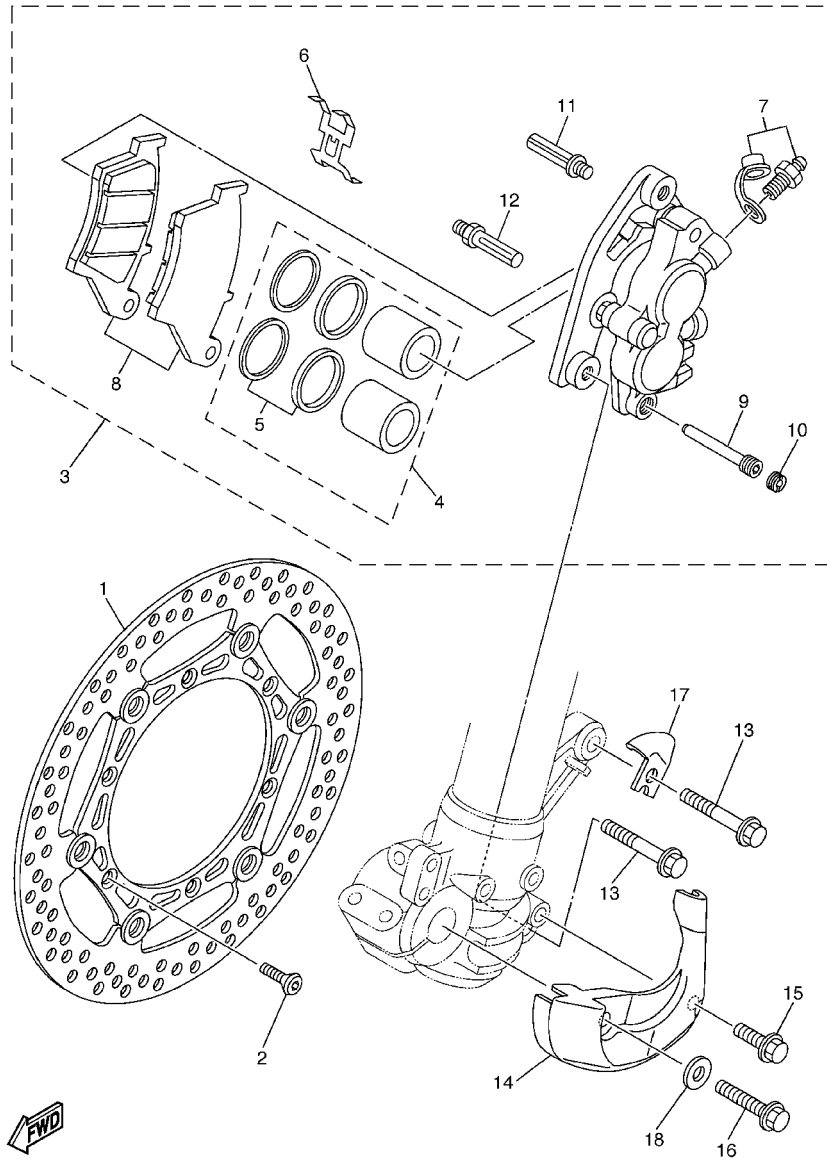

5SG1100-2290

REF. NO.	PART NO.	DESCRIPTION	5SG1	5SG2	5SG3	5SG4	REMARKS
1	5MV-2581T-00	DISC BRAKE ASSY	1	1	1	1	
2	90149-06327	SCREW	6	6	6	6	
3	5MV-2580T-10	CALIPER ASSY (LEFT)	1	1	1	1	
4	4EW-W0057-00	.PISTON ASSY, CALIPER	1	1	1	1	
5	3JD-W0047-00	..CALIPER SEAL KIT	1	1	1	1	
6	5DH-25919-00	.SUPPORT, PAD	1	1	1	1	
7	1UY-W0048-50	.BLEED SCREW KIT	1	1	1	1	
8	5MV-W0045-00	.BRAKE PAD KIT	1	1	1	1	
9	5DH-25933-00	.WASHER, PAD PIN	1	1	1	1	
10	5DH-25916-00	.PLUG	1	1	1	1	
11	3SP-25926-51	.BOLT	1	1	1	1	
12	3SP-25914-51	.PIN, SLIDE	1	1	1	1	
13	90105-08659	BOLT, FLANGE	2	2	2	2	
14	5DH-2314E-00	COVER, HOSE	1	1	1	1	
15	95827-06012	BOLT, FLANGE	1	1	1	1	
16	95027-08020	BOLT, FLANGE	1	1	1	1	
17	5DH-25875-00	HOLDER, BRAKE HOSE 1	1	1	1	1	
18	92907-08200	WASHER	1	1	1	1	

FIG. 30 REAR WHEEL

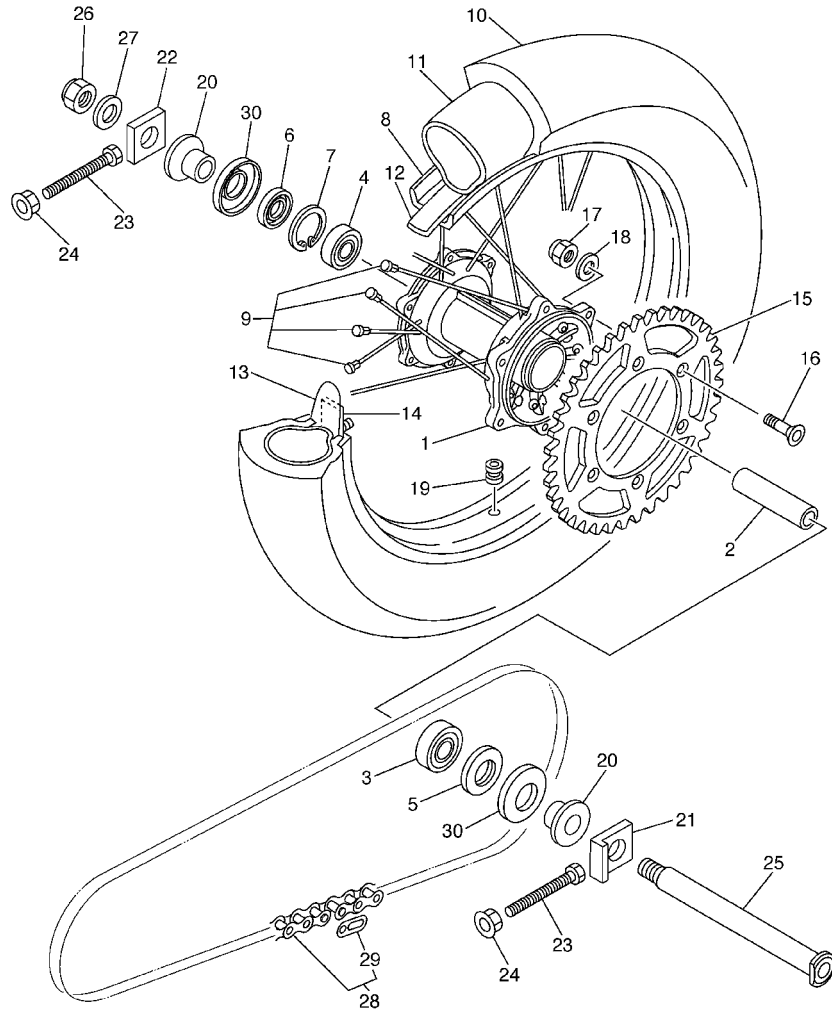

5SG1100-2300

REF. NO.	PART NO.	DESCRIPTION	5SG1	5SG2	5SG3	5SG4	REMARKS
1	5ET-25311-00	HUB, REAR	1	1	1	1	
2	5ET-25317-00	SPACER, BEARING	1	1	1	1	
3	93306-27205	BEARING	1	1	1	1	
4	93306-07202	BEARING	1	1	1	1	
5	93106-30044	OIL SEAL	1	1	1	1	
6	93106-30045	OIL SEAL	1	1	1	1	
7	99009-45500	CIRCLIP	1	1	1	1	
8	94418-19003	RIM (1.85-19)	1	1	1	1	
9	5HD-25304-00	SPOKE SET, REAR	1	1	1	1	
10	94110-1916A	TIRE (100/90-19 57M D739)	1			1	DUNLOP
	94110-1913B	TIRE (100/90-19 57M D755)		1		1	DUNLOP
	*	TIRE (100/90-19 MT320)		1			LM PIRELLI PIRE
	94110-1911A	TIRE (100/90-19 57M M78A)			1		BRIDGESTONE
11	94210-19222	TUBE(100/90-19)			1		BRIDGESTONE
	94210-19224	TUBE(100/90-19 TR4 BTL)	1	1		1	DUNLOP
	*	TUBE (110/90-19)		1			LM PIRELLI
12	94316-19156	BAND, RIM (1.85-19)			1		BRIDGESTONE
	94321-19135	BAND, RIM (90-100/90-19)	1	1		1	DUNLOP
	*	BAND, RIM (3.50-18)		1			LM METZELER
13	4XM-25394-00	SPACER, BEAD	1	1	1	1	
14	4XM-25364-00	DAMPER	1	1	1	1	
15	5NY-25448-00	SPROCKET, DRIVEN (48T)	1	1	1	1	STD
	5ET-25447-00	SPROCKET, DRIVEN (47T)	1	1	1	1	AP
	5NY-25449-00	SPROCKET, DRIVEN (49T)	1	1	1	1	AP
	5NY-25450-00	SPROCKET, DRIVEN (50T)	1	1	1	1	AP
	5NY-25451-00	SPROCKET, DRIVEN (51T)	1	1	1	1	AP
	5NY-25452-00	SPROCKET, DRIVEN (52T)	1	1	1	1	AP

FIG. 30 REAR WHEEL

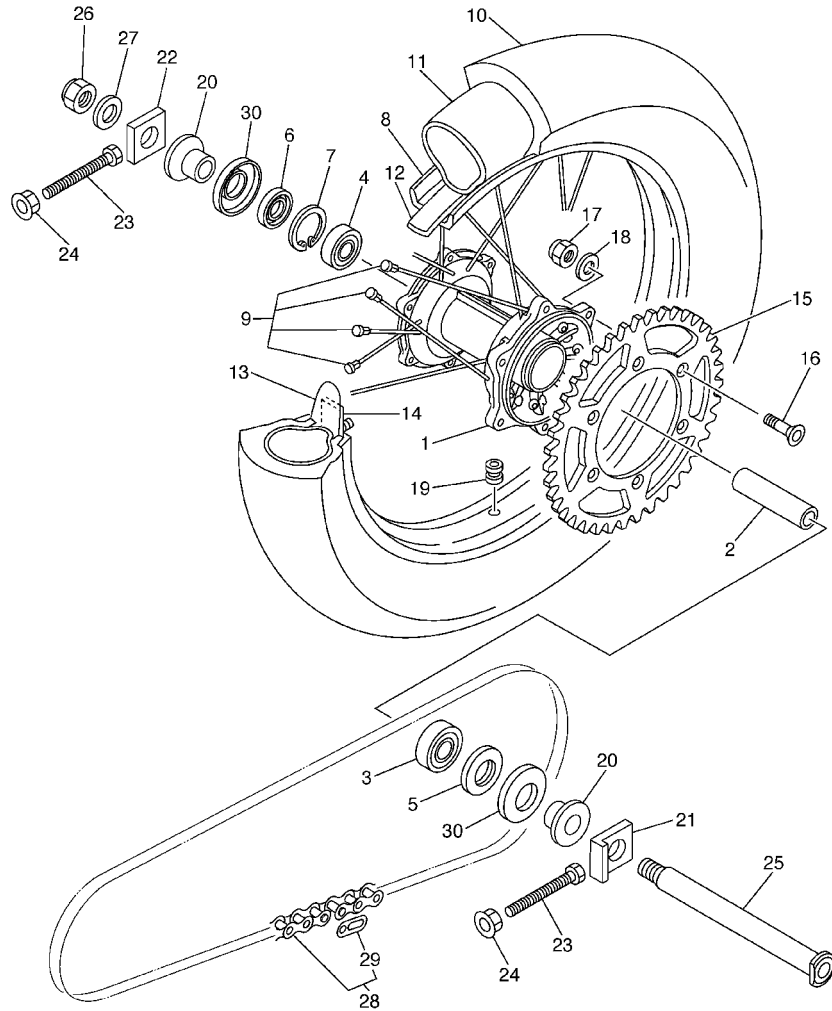

 5SG1100-2300

REF. NO.	PART NO.	DESCRIPTION	5SG1	5SG2	5SG3	5SG4	REMARKS
16	90109-081G1	BOLT	6	6	6	6	
17	90185-08169	NUT, SELF-LOCKING	6	6	6	6	
18	90201-08326	WASHER, PLATE	6	6	6	6	
19	90480-08608	GROMMET	1	1	1	1	
20	5NY-25383-00	COLLAR, WHEEL	2	2	2	2	
21	5NY-25388-00	PULLER, CHAIN 1	1	1	1	1	
22	5NY-25389-00	PULLER, CHAIN 2	1	1	1	1	
23	90101-08777	BOLT	2	2	2	2	
24	90179-08299	NUT	2	2	2	2	
25	5ET-25381-00	AXLE, WHEEL	1	1	1	1	
26	90185-20168	NUT, SELF-LOCKING	1	1	1	1	
27	90201-203U1	WASHER, PLATE	1	1	1	1	
28	9Y581-92111	CHAIN (DID 520D 112L)	1	1	1	1	
29	94681-68001	.JOINT,CHAIN (DID 520DM-RJ)	1	1	1	1	
30	5ET-25367-00	COVER, HUB DUST	2	2	2	2	

FIG. 31 REAR BRAKE CALIPER

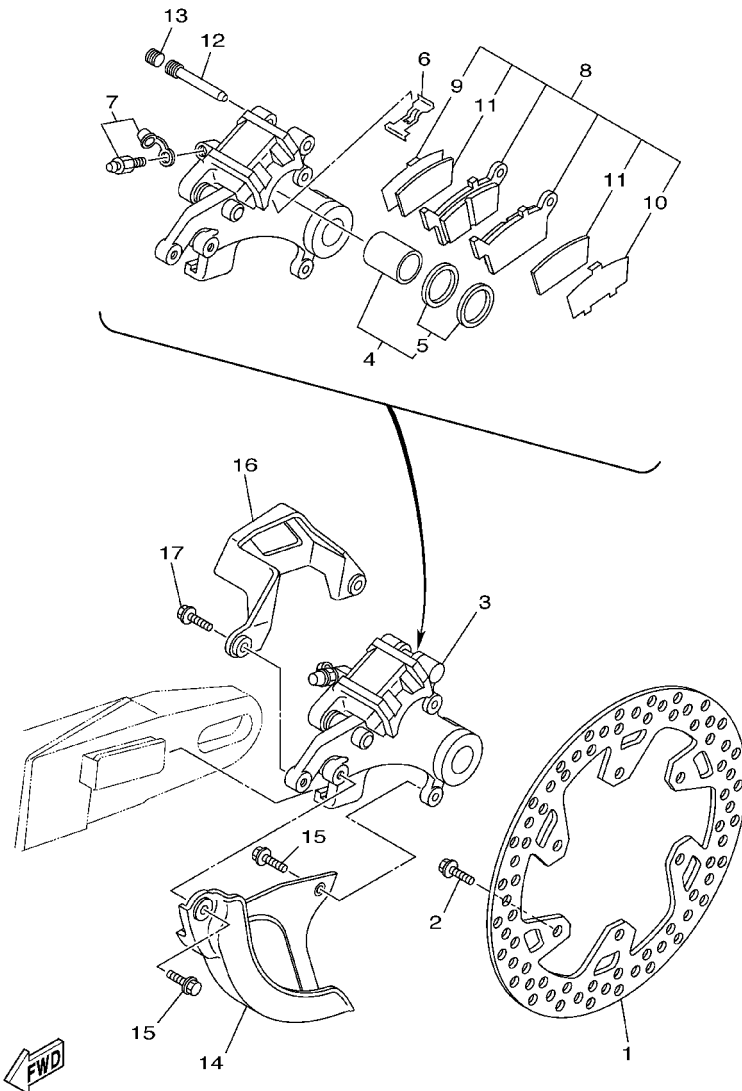

5NL1100-1310

REF. NO.	PART NO.	DESCRIPTION	SSG1	SSG2	SSG3	SSG4	REMARKS
1	5NY-2582W-00	DISC, REAR BRAKE 2	1	1	1	1	
2	90109-065G4	BOLT	6	6	6	6	
3	5NY-2580W-00	CALIPER ASSY, REAR 2	1	1	1	1	
4	5ET-W0057-50	.PISTON ASSY, CALIPER	1	1	1	1	
5	5ET-W0047-50	..CALIPER SEAL KIT	1	1	1	1	
6	5DH-25919-50	..SUPPORT, PAD	1	1	1	1	
7	1UY-W0048-50	..BLEED SCREW KIT	1	1	1	1	
8	5GR-W0046-00	..BRAKE PAD KIT 2	1	1	1	1	
9	5DH-25828-50	..SHIM, CALIPER	1	1	1	1	
10	5DH-25827-50	..SHIM, CALIPER	1	1	1	1	
11	5GR-22898-50	..INSULATOR, HEAT	2	2	2	2	
12	8CR-25924-00	..PIN, PAD	1	1	1	1	
13	5DH-25916-00	..PLUG	1	1	1	1	
14	5DH-25718-01	PROTECTOR, DISK BRAKE	1	1	1	1	
15	95027-06012	BOLT, FLANGE	2	2	2	2	
16	4GY-27491-00	PROTECTOR	1	1	1	1	
17	95027-06016	BOLT, FLANGE	2	2	2	2	

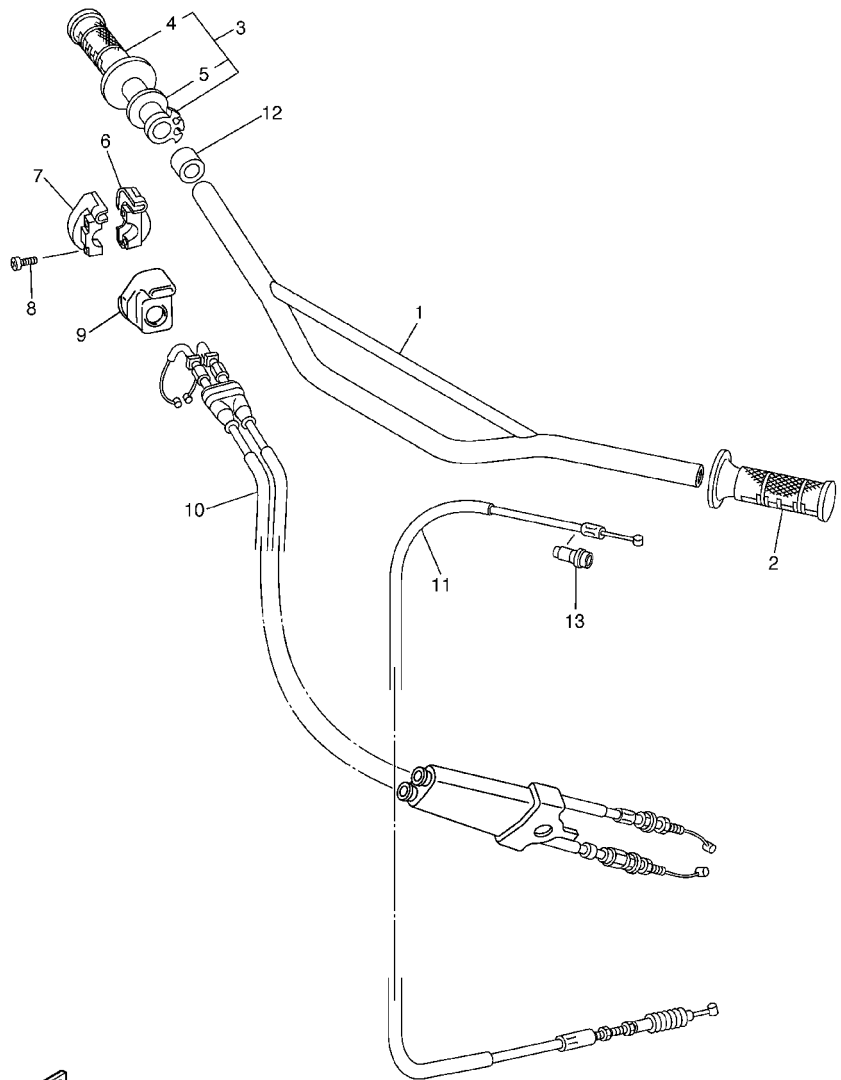
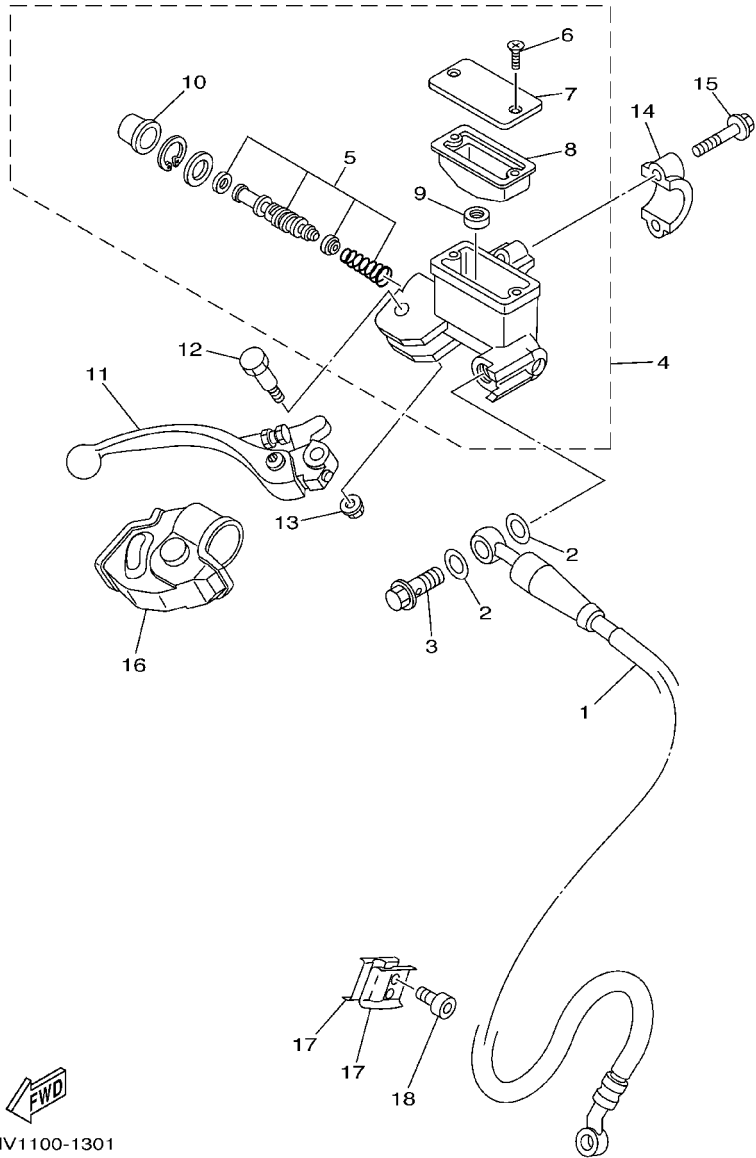

FIG. 32 STEERING HANDLE. CABLE

REF. NO.	PART NO.	DESCRIPTION	5SG1	5SG2	5SG3	5SG4	REMARKS
1	4XM-26111-00	HANDLEBAR	1	1	1	1	
2	4GY-26241-00	GRIP	1	1	1	1	
3	5BE-26240-00	GRIP ASSY	1	1	1	1	
4	4GY-26242-00	.GRIP (RIGHT)	1	1	1	1	
5	3Y1-26249-00	.RING, LEAF	1	1	1	1	
6	5BE-26281-00	CAP, GRIP UPPER	1	1	1	1	
7	5BE-26282-00	CAP, GRIP LOWER	1	1	1	1	
8	98507-05020	SCREW, PAN HEAD	2	2	2	2	
9	5SF-26287-00	COVER, CAP GRIP	1	1	1	1	
10	5SF-26302-00	THROTTLE CABLE ASSY	1	1	1	1	
11	5SF-26335-00	CABLE, CLUTCH	1	1	1	1	
12	90387-225N2	COLLAR	1	1	1	1	
13	5HD-26342-00	BOOT, CABLE	1	1	1	1	

5SG1100-2320

FIG. 33 FRONT MASTER CYLINDER



5MV1100-1301

REF. NO.	PART NO.	DESCRIPTION	SSG1	SSG2	SSG3	SSG4	REMARKS
1	5ET-25872-00	HOSE, BRAKE 1	1	1	1	1	
2	90201-10118	WASHER, PLATE	4	4	4	4	
3	90401-10172	BOLT, UNION	2	2	2	2	
4	5NY-W2587-01	MASTER CYLINDER SUB ASSY	1	1	1	1	
5	5NY-W0041-00	.CYLINDER KIT, MASTER	1	1	1	1	
6	98706-04012	.SCREW, FLAT HEAD	2	2	2	2	
7	5MV-25852-01	.CAP, RESERVOIR	1	1	1	1	
8	56A-25854-00	.DIAPHRAGM, RESERVOIR	1	1	1	1	
9	8CR-25715-00	.SEPARATOR ASSY	1	1	1	1	
10	5NY-25868-00	.BOOT, MASTER CYLINDER	1	1	1	1	
11	5MV-83922-00	LEVER 2	1	1	1	1	
12	5MV-2589F-00	BOLT, LEVER	1	1	1	1	
13	95701-06500	NUT, FLANGE	1	1	1	1	
14	5MV-25867-00	BRACKET, MASTER CYLINDER	1	1	1	1	
15	5MV-25833-00	BOLT, FITTING	2	2	2	2	
16	5NY-26372-00	COVER, HANDLE LEVER 1	1	1	1	1	
17	90465-16258	CLAMP	2	2	2	2	
18	91317-06014	BOLT	2	2	2	2	

FIG. 34 STAND, FOOTREST

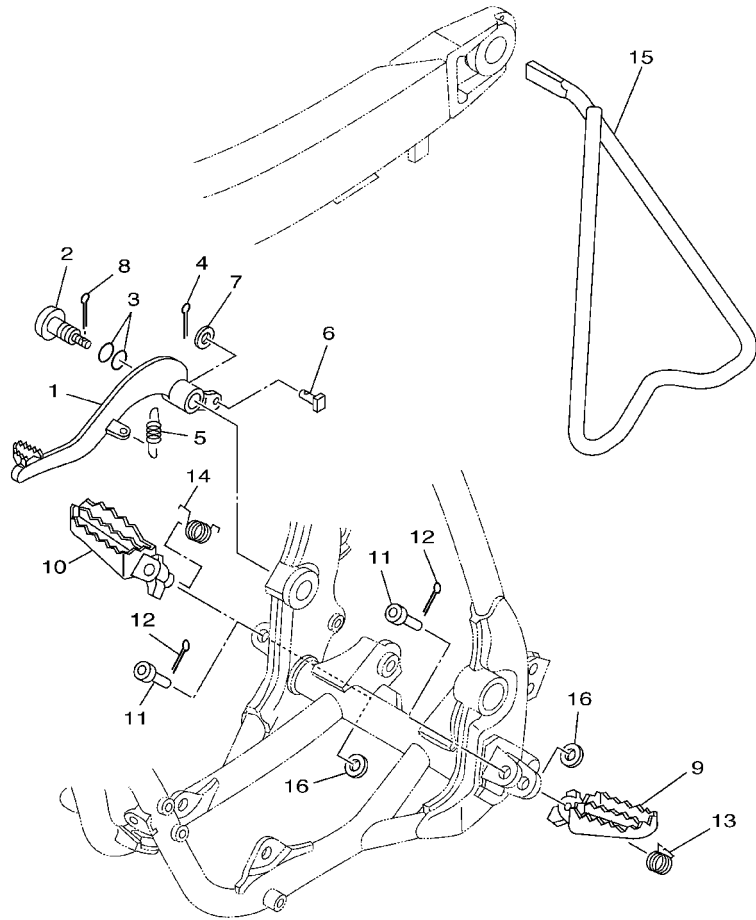

REF. NO.	PART NO.	DESCRIPTION	SSG1	SSG2	SSG3	SSG4	REMARKS
1	4XM-27200-00	PEDAL, BRAKE	1	1	1	1	
2	5JG-27217-00	BOLT	1	1	1	1	
3	93210-11073	O-RING	2	2	2	2	
4	91401-20012	PIN, COTTER	1	1	1	1	
5	90506-16500	SPRING, TENSION	1	1	1	1	
6	90240-08120	PIN, CLEVIS	1	1	1	1	
7	90201-08089	WASHER, PLATE	1	1	1	1	
8	90468-16191	CLIP	1	1	1	1	
9	5ET-27411-00	FOOTREST 1	1	1	1	1	
10	5ET-27421-00	FOOTREST 2	1	1	1	1	
11	90240-10142	PIN, CLEVIS	2	2	2	2	
12	91401-25015	PIN, COTTER	2	2	2	2	
13	90508-282B8	SPRING, TORSION	1	1	1	1	
14	90508-282B9	SPRING, TORSION	1	1	1	1	
15	5ET-27311-00	STAND, SIDE	1	1	1	1	
16	90201-10119	WASHER, PLATE	2	2	2	2	



5NL1100-1340

FIG. 35 REAR MASTER CYLINDER

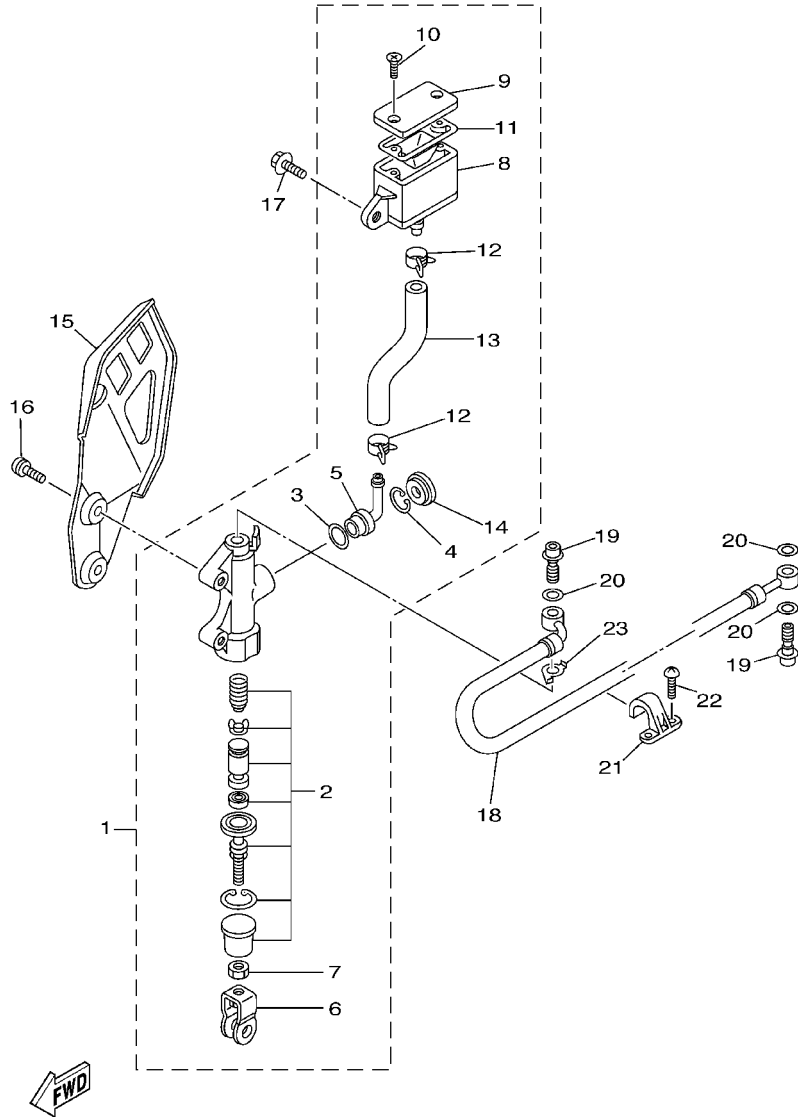

5NL1100-1350

REF. NO.	PART NO.	DESCRIPTION	SSG1	SSG2	SSG3	SSG4	REMARKS
1	5JG-2583V-00	RR. MASTER CYLINDER ASSY.	1	1	1	1	
2	4SS-W0042-50	.CYLINDER KIT, MASTER	1	1	1	1	
3	93210-15620	.O-RING	1	1	1	1	
4	2VN-25866-00	.CIRCLIP	1	1	1	1	
5	4ML-2582A-50	.JOINT	1	1	1	1	
6	3SP-27222-00	.JOINT	1	1	1	1	
7	95301-08700	.NUT	2	2	2	2	
8	5BE-25894-00	.TANK, RESERVOIR	1	1	1	1	
9	5BE-25852-00	.CAP, RESERVOIR	1	1	1	1	
10	98706-04040	.SCREW, FLAT HEAD	2	2	2	2	
11	56A-25854-00	.DIAPHRAGM, RESERVOIR	1	1	1	1	
12	90467-12085	.CLIP	2	2	2	2	
13	5BE-25895-00	.HOSE, RESERVOIR	1	1	1	1	
14	3FV-2589A-00	.COVER, DUST	1	1	1	1	
15	5BE-2117M-01	COVER 2	1	1	1	1	
16	92014-06016	BOLT, BUTTON HEAD	2	2	2	2	
17	90105-06553	BOLT, FLANGE	1	1	1	1	
18	5MV-25873-00	HOSE, BRAKE 2	1	1	1	1	
19	90401-10172	BOLT, UNION	2	2	2	2	
20	90201-10118	WASHER, PLATE	3	3	3	3	
21	2VM-25876-00	HOLDER, BRAKE HOSE 2	2	2	2	2	
22	90157-05095	SCREW, PAN HEAD	4	4	4	4	
23	5BE-25844-01	WASHER, LOCK	1	1	1	1	

FIG. 36 GENERATOR

REF. NO.	PART NO.	DESCRIPTION	5SG1	5SG2	5SG3	5SG4	REMARKS
1	5SF-85560-00	BASE ASSY	1	1	1	1	
2	5JG-85550-11	ROTOR ASSY	1	1	1	1	
3	90149-06324	SCREW	3	3	3	3	
4	90179-10247	NUT	1	1	1	1	
5	90201-101J1	WASHER, PLATE	1	1	1	1	

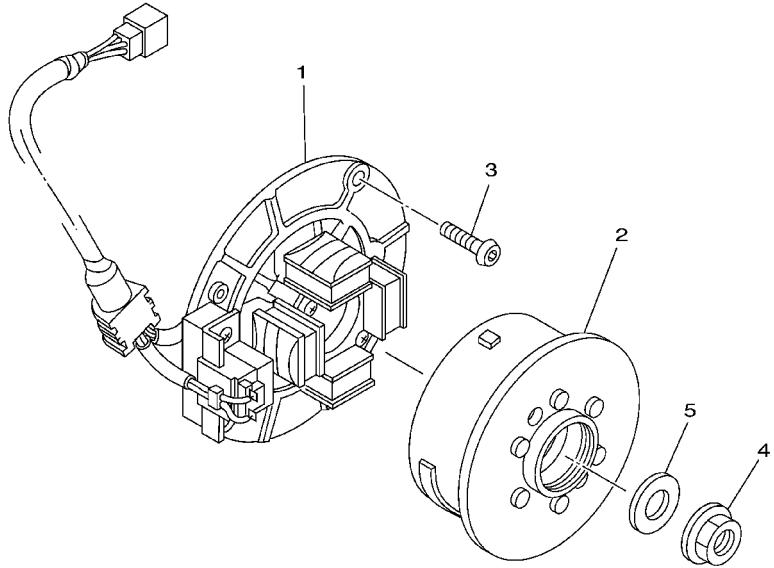

5NL1100-1360

FIG. 37 HANDLE SWITCH. LEVER

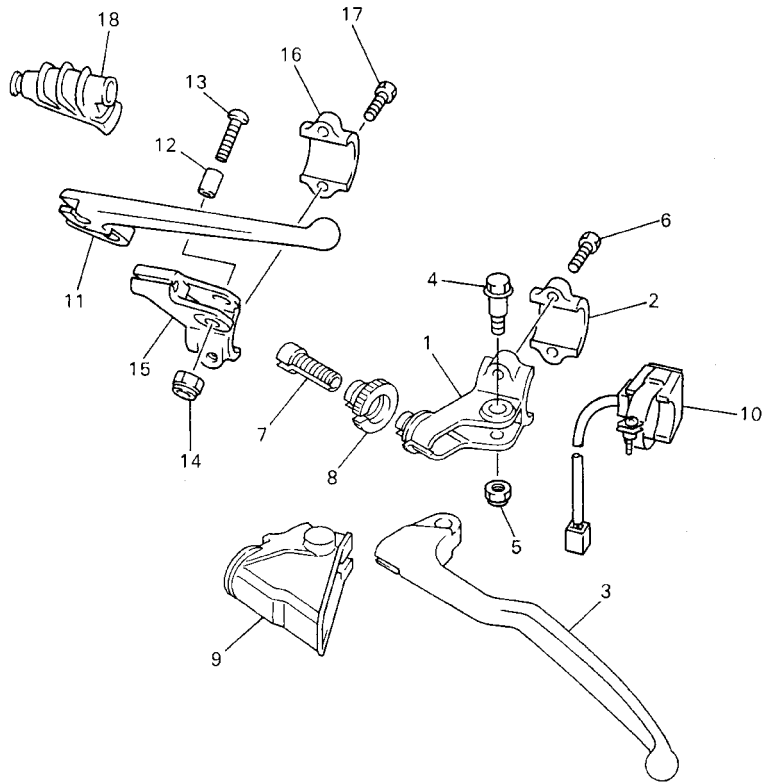

REF. NO.	PART NO.	DESCRIPTION	5SG1	5SG2	5SG3	5SG4	REMARKS
1	5HD-82911-00	HOLDER, LEVER 1	1	1	1	1	
2	38V-82913-00	HOLDER, LEVER LOWER 1	1	1	1	1	
3	5MV-83912-00	LEVER 1	1	1	1	1	
4	90109-06027	BOLT	1	1	1	1	
5	95607-06100	NUT, U	1	1	1	1	
6	97007-05016	BOLT	2	2	2	2	
7	5HD-26337-00	BOLT, ADJUSTING	1	1	1	1	
8	5HD-83951-00	BOLT, CABLE ADJUSTING	1	1	1	1	
9	5HD-26372-00	COVER, HANDLE LEVER 1	1	1	1	1	
10	5SF-83976-00	SWITCH, HANDLE 1	1	1	1	1	
11	583-83981-00	LEVER, DECOMPRESSION	1	1	1	1	
12	5BE-83913-00	COLLAR, LEVER 1	1	1	1	1	
13	98907-05020	SCREW, BIND	1	1	1	1	
14	95607-05100	NUT, U	1	1	1	1	
15	5BE-82912-00	HOLDER, LEVER UPPER 1	1	1	1	1	
16	38V-82913-00	HOLDER, LEVER LOWER 1	1	1	1	1	
17	97007-05016	BOLT	2	2	2	2	
18	583-26352-00	COVER, DECOMPRESSION CABLE	1	1	1	1	



5JG1100-0370

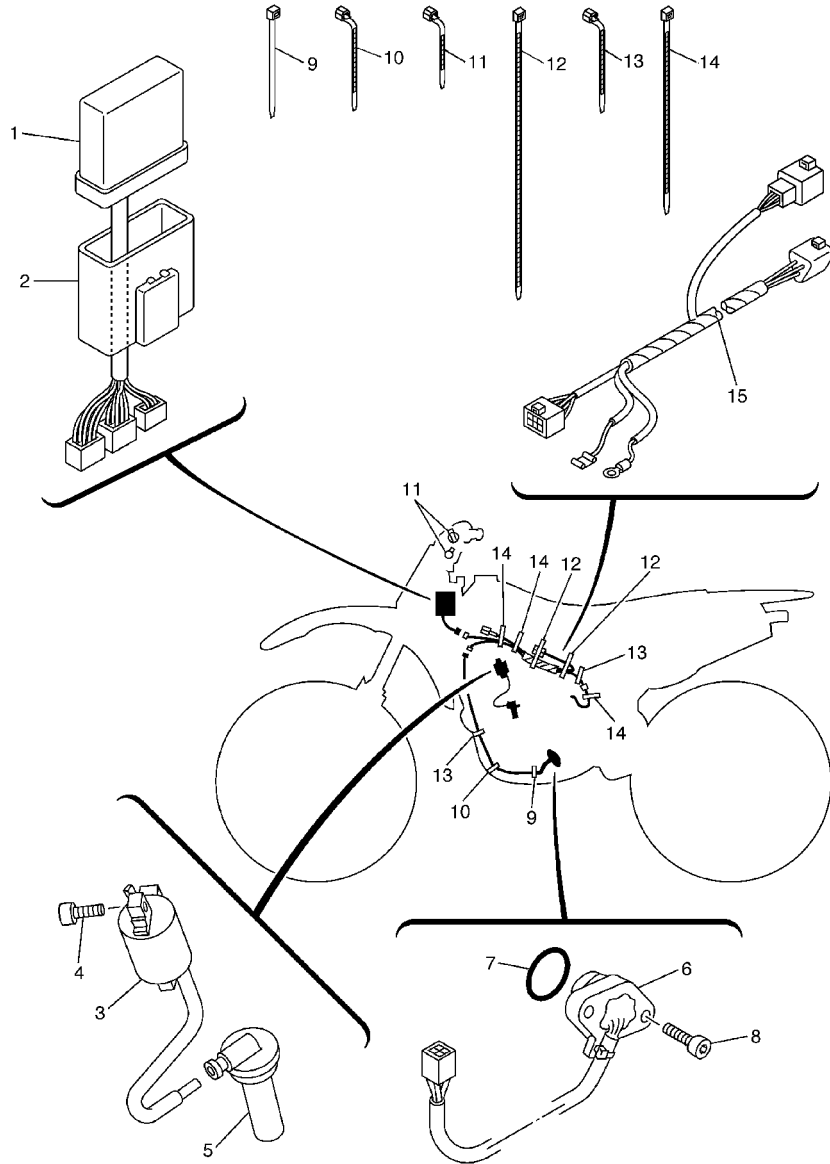

5SG1100-2380

FIG. 38 ELECTRICAL 1

REF. NO.	PART NO.	DESCRIPTION	5SG1	5SG2	5SG3	5SG4	REMARKS
1	5SG-85540-00	C.D.I. UNIT ASSY	1	1	1	1	
2	5NL-85546-00	BAND	1	1	1	1	
3	4SR-82310-00	IGNITION COIL ASSY	1	1	1	1	
4	91317-06016	BOLT	2	2	2	2	
5	5BE-82370-00	PLUG CAP ASSY	1	1	1	1	
6	5SF-82540-00	NEUTRAL SWITCH ASSY	1	1	1	1	
7	93210-21276	O-RING	1	1	1	1	
8	90154-05073	SCREW, BINDING	2	2	2	2	
9	90464-16061	CLAMP	1	1	1	1	
10	90464-13073	CLAMP	1	1	1	1	
11	90464-13077	CLAMP	2	2	2	2	
12	90464-15152	CLAMP	2	2	2	2	
13	90464-13073	CLAMP	3	3	3	3	
14	90465-13275	CLAMP	2	2	2	2	
15	5SG-82509-00	WIRE, SUB LEAD	1	1	1	1	

FIG. 39 ALTERNATE (CHASSIS)

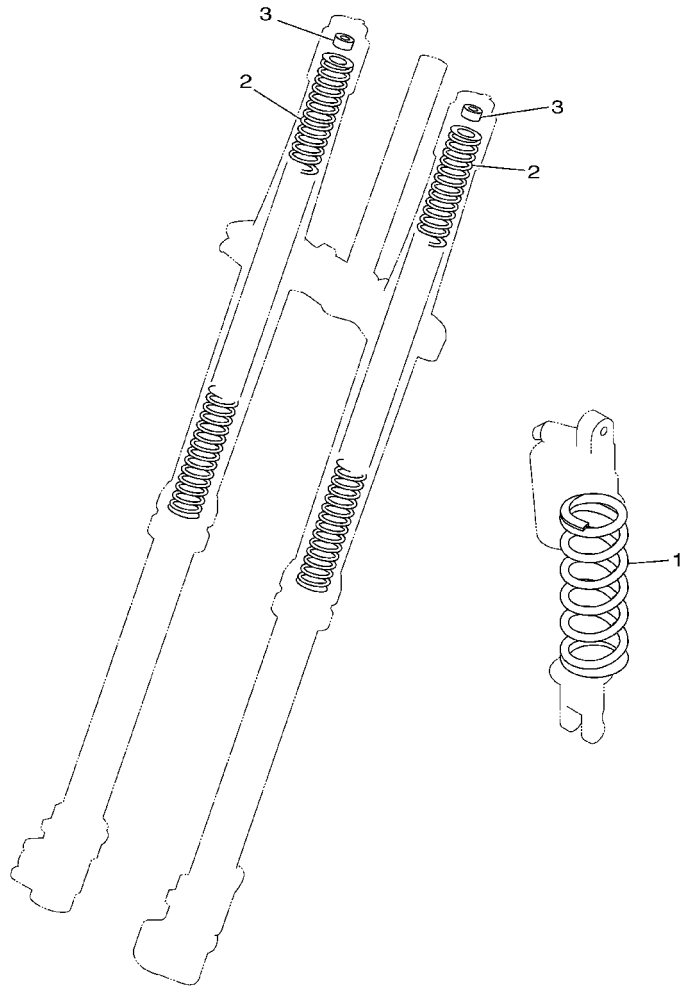

5NL1100-1390

REF. NO.	PART NO.	DESCRIPTION	5SG1	5SG2	5SG3	5SG4	REMARKS
1	5DH-22212-70	SPRING (K=4.4)	1	1	1	1	AP
	5DH-22212-10	SPRING (K=4.6)	1	1	1	1	AP
	5DH-22212-20	SPRING (K=4.8)	1	1	1	1	AP
	5NG-22212-60	SPRING (K=5.0)	1	1	1	1	AP
	5DH-22212-40	SPRING (K=5.2)	1	1	1	1	AP
	5SF-22212-00	SPRING (K=5.4)	1	1	1	1	AP
	5DH-22212-60	SPRING (K=5.6)	1	1	1	1	AP
	5NG-22212-20	SPRING (K=APPROX.4.6)	1	1	1	1	AP
	5ET-22212-00	SPRING (K=APPROX.4.8)	1	1	1	1	AP
	5ET-22212-10	SPRING (K=APPROX.5.0)	1	1	1	1	AP
	5ET-22212-30	SPRING (K=APPROX.5.2)	1	1	1	1	AP
	5ET-22212-40	SPRING (K=APPROX.5.4)	1	1	1	1	AP
	5NG-22212-50	SPRING (K=APPROX.5.6)	1	1	1	1	AP
2	4SS-23141-10	SPRING, FRONT FORK (K=0.38)	2	2	2	2	AP
	4SS-23141-20	SPRING, FRONT FORK (K=0.39)	2	2	2	2	AP
	4SS-23141-30	SPRING, FRONT FORK (K=0.40)	2	2	2	2	AP
	4SS-23141-40	SPRING, FRONT FORK (K=0.41)	2	2	2	2	AP
	4SS-23141-50	SPRING, FRONT FORK (K=0.42)	2	2	2	2	AP
	4SS-23141-60	SPRING, FRONT FORK (K=0.43)	2	2	2	2	AP
	4SS-23141-70	SPRING, FRONT FORK (K=0.44)	2	2	2	2	AP
	5BE-23141-L0	SPRING, FRONT FORK (K=0.45)	2	2	2	2	AP
	5BE-23141-00	SPRING, FRONT FORK (K=0.46)	2	2	2	2	AP
	5GR-23141-00	SPRING, FRONT FORK (K=0.47)	2	2	2	2	AP
	5ET-23141-20	SPRING (K=APPROX.0.40)	2	2	2	2	AP
	5ET-23141-00	SPRING (K=APPROX.0.41)	2	2	2	2	AP
	5ET-23141-30	SPRING (K=APPROX.0.42)	2	2	2	2	AP
	5ET-23141-10	SPRING (K=APPROX.0.43)	2	2	2	2	AP

FIG. 39 ALTERNATE (CHASSIS)

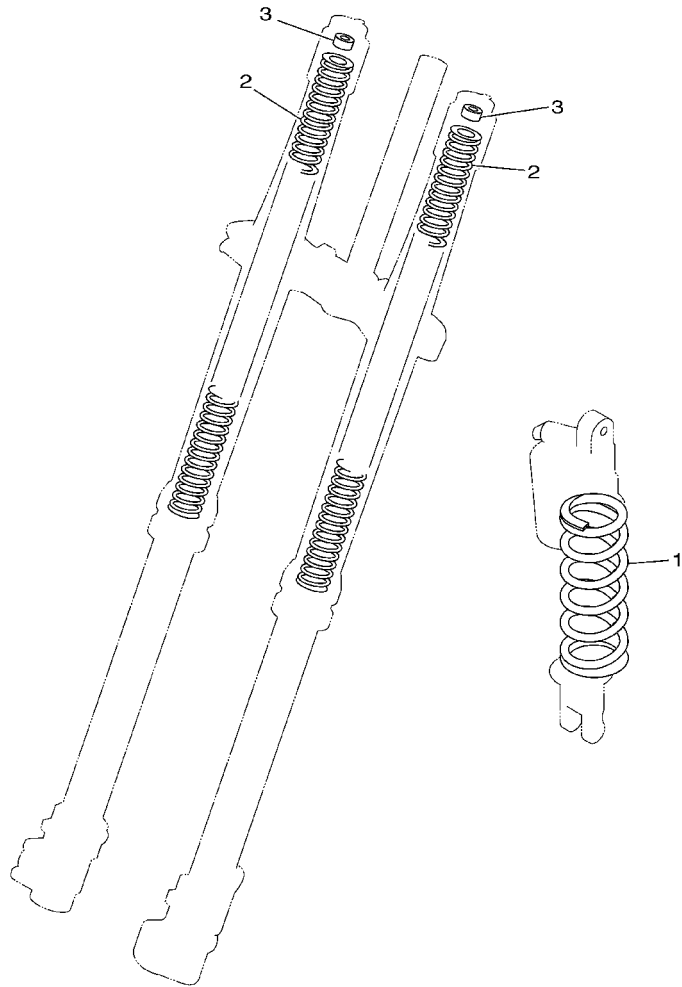

REF. NO.	PART NO.	DESCRIPTION	5SG1	5SG2	5SG3	5SG4	REMARKS
2	5ET-23141-40	SPRING (K=APPROX.0.44)	2	2	2	2	AP
3	4SS-23364-L0	COLLAR 2	2	2	2	2	UN AP



5NL1100-1390

NUMERICAL INDEX

PART NO.	GRID NO.	PART NO.	GRID NO.	PART NO.	GRID NO.	PART NO.	GRID NO.	PART NO.	GRID NO.	PART NO.	GRID NO.
5NY-W0041-00	E - 6	3GM-12126-00	B - 5	5NL-12459-00	B - 8	5JG-1440F-01	B - 13	3TJ-1494F-13	B - 15	5JG-14959-00	B - 14
4SS-W0042-50	E - 8	3FV-12153-00	B - 6	5NL-12461-00	B - 9	5JG-14401-00	B - 13	3TJ-1494F-14	B - 15	5JG-14984-00	C - 2
5MV-W0045-00	D - 15	3FV-12153-10	B - 6	5HD-12462-00	B - 9	5BE-1441A-10	B - 13	3TJ-1494F-15	B - 15	4SR-14985-00	C - 2
5GR-W0046-00	E - 4	3FV-12153-20	B - 6	5NL-12481-00	B - 9	5BE-1441E-10	B - 13	3TJ-1494F-16	B - 15	5JG-14987-00	C - 3
3JD-W0047-00	D - 15	3FV-12153-30	B - 6	5NL-12564-00	C - 6	5JG-14417-00	B - 13	3TJ-1494F-17	B - 15	4FN-14997-00	B - 14
5ET-W0047-50	E - 4	3LN-12153-00	B - 6	5SG-12576-00	B - 9	5JG-14428-00	B - 13	3TJ-1494F-18	B - 15	5SG-15150-00	C - 5
1UY-W0048-50	D - 15	3LN-12153-10	B - 6	5SG-12577-00	B - 9	5BE-1443E-00	B - 13	3TJ-1494F-19	B - 15	5NL-15362-00	C - 15
	E - 4	3LN-12153-20	B - 6	5SG-12578-00	B - 9	5BE-14449-00	C - 2	3TJ-1494F-20	B - 15	4JT-15381-01	C - 5
4EW-W0057-00	D - 15	3LN-12153-30	B - 6	5SG-12579-00	B - 9	4XM-14451-00	B - 13	4JT-1494F-13	C - 3	5BE-15383-01	C - 5
5ET-W0057-50	E - 4	1HX-12168-A0	B - 5	583-13113-00	B - 12	5JG-14453-00	B - 13	4JT-1494F-15	C - 3	5NL-15388-00	C - 5
5NY-W2587-01	E - 6	1HX-12168-F0	B - 5	5NL-13161-00	B - 12	5BE-14458-00	B - 13	4JT-1494F-17	C - 3	5NL-15411-00	C - 6
5NL-11102-10	B - 2	1HX-12168-H1	B - 5	5NL-13171-00	B - 12	3JD-14459-01	B - 13	4JT-1494F-19	C - 3	5NL-15415-00	C - 6
4KG-1111G-00	B - 3	1HX-12168-K1	B - 5	5SG-13300-00	B - 10	5MV-14477-00	B - 13	4JT-1494F-21	C - 3	5BE-15421-00	C - 5
5NL-11133-10	B - 2	1HX-12168-M1	B - 5	5NL-13320-00	B - 10	5JG-14521-00	B - 14	4JT-1494F-23	C - 3	5NL-15431-00	C - 6
5NL-11134-10	B - 2	1HX-12168-R1	B - 5	5NL-13341-00	B - 10	5JG-14522-00	B - 14	4JT-1494F-25	C - 3	5NL-15441-01	C - 5
5BE-11166-00	B - 3	1HX-12168-U1	B - 5	5BE-13342-00	B - 10	5JG-14531-00	C - 3	4JT-1494F-27	C - 3	5NL-15451-00	C - 6
371-11167-01	B - 3	1HX-12168-W1	B - 5	5NL-13411-00	B - 10	3TJ-14536-40	C - 2	4JT-1494F-28	C - 3	5NL-15453-00	C - 6
5BE-11167-00	B - 3	1HX-12168-Y1	B - 5	5NL-13412-00	B - 10	5JG-14546-01	B - 14	4JT-1494F-29	C - 3	5NL-15462-00	C - 6
5NL-11181-00	B - 2	1HX-12168-00	B - 5	5NL-13416-00	B - 10	676-14548-00	C - 2	4JT-1494F-30	C - 3	5NL-15601-00	C - 7
5NL-11191-00	B - 2	1HX-12168-20	B - 5	1UY-13440-02	B - 12	4YR-14557-00	C - 2	4JT-1494F-31	C - 3	5NL-15620-00	C - 7
5NL-11193-00	B - 3	1HX-12168-40	B - 5	5BE-13447-00	B - 12	4FN-14561-00	B - 13	4JT-1494F-32	C - 3	5NL-15621-00	C - 7
5NL-11311-00	B - 3	1HX-12168-60	B - 5	5NL-13464-00	B - 10	4MX-14561-00	C - 2	4JT-1494F-33	C - 3	5NL-15641-00	C - 7
5NL-11351-00	B - 3	1HX-12168-80	B - 5	5NL-13465-00	B - 10	6H4-14561-00	C - 2	5JG-14940-16	C - 2	5NL-15651-00	C - 7
5JG-11387-00	B - 3	1HX-12169-E0	B - 6	5NL-13597-10	B - 13	5BE-14562-00	C - 2	5JG-14940-17	C - 2	5NL-15664-00	C - 7
5NL-11400-10	B - 4	1HX-12169-G0	B - 6	5SG-14101-00	B - 14	5JG-14565-00	C - 3	5JG-14940-18	C - 2	5SG-15668-00	C - 7
5NL-11412-00	B - 4	1HX-12169-J0	B - 6	5SG-14101-10	B - 14	5NL-14591-00	C - 3	5JG-14940-76	C - 2	4GY-15671-00	C - 7
5NL-11422-00	B - 4	1HX-12169-L0	B - 6	3TJ-14105-40	C - 2	5NL-14611-00	C - 4	3TJ-14943-47	B - 15	214-15686-00	C - 7
5NL-11454-00	B - 4	1HX-12169-N0	B - 6	5BE-14107-00	C - 2	5NL-14613-00	C - 4	4MX-14943-40	B - 14	5NL-16111-00	C - 8
5NL-11455-00	B - 4	1HX-12169-T0	B - 6	4MX-14115-00	C - 3	5NL-14628-00	C - 4	4MX-14943-41	B - 15	5NL-16150-10	C - 8
5NL-11531-00	B - 4	1HX-12169-11	B - 6	3TJ-14137-40	C - 3	5NL-1469A-00	C - 4	4MX-14943-42	B - 15	5NL-16154-00	C - 8
5NL-11536-00	B - 4	1HX-12169-31	B - 6	5BE-14146-00	C - 3	5BE-1469E-00	C - 4	4MX-14943-43	B - 15	3XJ-16321-00	C - 8
5NL-11603-00	B - 4	1HX-12169-50	B - 6	3TJ-14159-40	B - 14	5BE-14747-00	C - 4	4MX-14943-44	B - 15	5DH-16321-00	C - 8
5NL-11631-00	B - 4	1HX-12169-70	B - 6	5JG-14171-00	C - 2	5NL-14753-00	C - 4	4MX-14943-45	B - 15	5NL-16325-00	C - 8
5NL-11633-00	B - 4	1HX-12169-90	B - 6	3TJ-14191-40	C - 3	5NL-14753-10	C - 4	4MX-14943-91	B - 15	5NL-16325-10	C - 8
5NL-11651-10	B - 4	5NL-12170-00	B - 7	5NL-14196-00	C - 3	3VD-14755-00	C - 4	4MX-14943-92	B - 15	5HD-16351-00	C - 8
5NL-11681-00	B - 4	5NL-12180-00	B - 7	5JG-14197-00	C - 3	4BD-14766-00	C - 4	4MX-14943-93	B - 14	5NL-16356-00	C - 8
5NL-12111-00	B - 5	5BE-12210-00	B - 7	4YR-14216-00	C - 2	5NL-14788-00	C - 4	4MX-14943-94	B - 15	5NL-16357-00	C - 8
5NL-12112-00	B - 5	4FM-12213-00	B - 7	5BE-14216-00	C - 2	5JG-14916-EL	B - 14	4MX-14943-95	B - 15	5NL-16371-00	C - 8
5NL-12113-00	B - 5	5BE-12241-00	B - 7	5JG-14264-00	B - 14	5JG-14916-EM	B - 14	7A9-14943-27	B - 15	5JG-16381-00	C - 8
5NL-12114-00	B - 5	5NL-12251-00	B - 7	3TJ-14267-40	B - 14	5JG-14916-EN	B - 14	5JG-14947-00	B - 14	5NL-16383-10	C - 8
5NL-12116-00	B - 5	5NL-12252-00	B - 7	5JG-14275-00	B - 14	5JG-14916-EP	B - 14	4MX-14948-01	B - 15	4JT-16384-00	C - 8
1HX-12117-00	B - 5	5BE-12280-10	B - 7	3TJ-14293-40	C - 2	5JG-14916-ER	B - 14	4MX-14948-02	B - 15	5NL-16384-00	C - 8
1WG-12117-00	B - 5	5NL-12283-00	B - 7	5JG-14293-01	B - 13	5JG-14916-ES	B - 14	4MX-14948-03	B - 15	5NL-17121-00	C - 10
1HX-12118-00	B - 5	5BE-12292-10	B - 7	3TJ-14325-40	C - 2	5JG-14916-E1	B - 14	4MX-14948-04	B - 15	5NL-17131-00	C - 10
1WG-12118-00	B - 5	5NL-1240A-00	B - 9	5JG-14346-00	C - 3	5JG-14922-00	C - 2	4MX-14948-05	B - 15	5NL-17141-00	C - 10
4SV-12119-00	B - 5	5NL-12422-00	B - 8	5JG-14371-00	C - 2	3TJ-14933-40	C - 2	4MX-14948-06	B - 15	5NL-17151-00	C - 10
4TV-12119-00	B - 5	5NL-12439-00	B - 8	5JG-14379-00	C - 2	4FN-14934-00	C - 2	4MX-14948-07	B - 15	5NL-17211-10	C - 10
5NL-12121-00	B - 5	5DH-12451-00	B - 8	5JG-14388-00	B - 14	3TJ-1494F-12	B - 15	5JG-14951-00	B - 14	5NL-17221-00	C - 10

NUMERICAL INDEX

PART NO.	GRID NO.	PART NO.	GRID NO.	PART NO.	GRID NO.	PART NO.	GRID NO.	PART NO.	GRID NO.	PART NO.	GRID NO.
5NL-17231-00	C-10	5NL-21741-00	D-3	3SP-22234-00	D-6	5NL-23141-00	D-10	3JD-24186-00	D-12	56A-25854-00	E-6
5NL-17241-00	C-10	3JD-21748-00	D-2	5NY-22241-00	D-7	5DH-23142-L0	D-9	5SF-24240-01	D-12		E-8
5NL-17251-00	C-10	5MV-2175C-00	D-3	5DH-22253-00	D-6		D-10	3XJ-24380-00	D-12	2VN-25866-00	E-8
5NL-17411-10	C-10	5BE-21756-00	C-14	5MV-22253-00	D-6	5HD-23144-L0	D-9	4DP-24500-00	D-12	5MV-25867-00	E-6
5NL-17421-00	C-10	5JG-21781-50	D-3	5NY-22355-00	D-4		D-10	4X8-24512-00	D-12	5NY-25868-00	E-6
5NL-17466-00	C-5	5NY-22110-00	D-4	3V6-22358-00	D-12	5ET-23145-L0	D-9	3AJ-24523-00	D-12	5ET-25872-00	E-6
5NL-17471-00	C-11	5NY-22121-00	D-4	4EW-22474-00	D-6		D-10	3AJ-24534-00	D-12	5MV-25873-00	E-8
5NL-18101-00	C-13	5NY-22122-00	D-5	3JE-22475-00	D-6	4SS-23146-L0	D-9	5MV-24610-00	D-12	5DH-25875-00	D-15
5NL-18110-00	C-13	4XM-22128-00	D-4	5NY-22475-00	D-6		D-10	5SF-24710-00	D-13	2VM-25876-00	E-8
5LP-18122-00	C-13	5NY-22141-00	D-4	5GR-22898-50	E-4	5DH-23149-L0	D-9	5BE-24728-00	D-13	3FV-2589A-00	E-8
3XK-18140-00	C-12	5MV-22151-00	D-4	5SG-23102-00	D-9		D-10	5SF-24731-00	D-13	5MV-2589F-00	E-6
5BE-18172-00	C-13	5JG-22156-00	D-4	5SG-23102-10	D-9	4SS-23153-L0	D-9	5NY-25104-00	D-14	5BE-25894-00	E-8
3XJ-18173-00	C-13	5NY-2217A-00	D-4	5SG-23103-00	D-9		D-10	5NY-25111-00	D-14	5BE-25895-00	E-8
3XJ-18178-00	C-13	5NY-2217F-00	D-5	5SG-23103-10	D-9	4SS-23158-L0	D-9	5NY-25117-00	D-14	3SP-25914-51	D-15
3XJ-18182-00	C-13	5MV-22176-00	D-6	5BF-23110-L0	D-10		D-10	5BE-25181-00	D-14	5DH-25916-00	D-15
3XJ-18184-00	C-13	3JD-22178-10	C-14	5NY-23111-L0	D-9	5SG-2316A-00	D-9	5NY-25183-00	D-14		E-4
4EW-18185-00	C-13	4EW-22178-00	C-14		D-10		D-10	5NY-25186-00	D-14	5DH-25919-00	D-15
5NL-18501-10	C-12	5MV-22184-00	D-6	5DH-23118-L0	D-9	5SG-2316A-10	D-9	5HD-25304-00	E-2	5DH-25919-50	E-4
5NL-18502-10	C-12	4XM-22199-00	D-4		D-10		D-10	5ET-25311-00	E-2	8CR-25924-00	E-4
5NL-18503-10	C-12	5SG-22201-00	D-6	3JD-2312G-L0	D-9	5NY-23170-L0	D-9	5ET-25317-00	E-2	3SP-25926-51	D-15
5NL-18541-00	C-12	5SG-22201-10	D-6		D-10		D-10	4XM-25364-00	E-2	5DH-25933-00	D-15
4BA-18542-00	C-12	5SG-22201-20	D-6	5DH-23120-L0	D-9	5ET-23171-L0	D-9	5ET-25367-00	E-3	4XM-26111-00	E-5
5DH-18562-00	C-5	5SG-22201-30	D-6	5ET-23125-L0	D-9		D-10	5ET-25381-00	E-3	5BE-26240-00	E-5
5SG-21101-00	C-14	5SG-22201-40	D-6		D-10	5DH-23183-00	D-6	5NY-25383-00	E-3	4GY-26241-00	E-5
5BE-2117M-01	E-8	5SG-22210-00	D-6	5HD-23136-L0	D-9	509-23184-L0	D-6	5NY-25388-00	E-3	4GY-26242-00	E-5
5SF-21190-00	C-14	5SG-22210-10	D-6	5DH-2314E-00	D-15	5MV-23195-L0	D-9	5NY-25389-00	E-3	3Y1-26249-00	E-5
5HD-2135F-00	D-5	5SG-22210-20	D-6	5DH-2314F-L0	D-10		D-10	4XM-25394-00	E-2	5BE-26281-00	E-5
5NY-2135F-00	D-5	5SG-22210-30	D-6	4SS-2314G-L0	D-10	5HC-2331E-00	D-11	5SF-25394-00	D-14	5BE-26282-00	E-5
5NL-21417-00	C-15	5SG-22210-40	D-6	5DH-2314H-00	D-11	5SG-23340-00	D-10	5ET-25447-00	E-2	5SF-26287-00	E-5
5NL-21417-10	C-15	5DH-22212-10	E-12	5DH-2314J-00	D-10	4SS-23346-L0	D-10	5NY-25448-00	E-2	5SF-26302-00	E-5
5NL-21425-00	C-14	5DH-22212-20	D-6	4SS-23141-10	E-12	5NY-23346-L0	D-10	5NY-25449-00	E-2	5SF-26335-00	E-5
5NL-21425-10	C-14		E-12	4SS-23141-20	E-12	3SP-23356-L0	D-11	5NY-25450-00	E-2	5HD-26337-00	E-10
5NL-2147A-00	C-15	5DH-22212-40	E-12	4SS-23141-30	E-12	4SS-23364-L0	E-13	5NY-25451-00	E-2	5HD-26342-00	E-5
5NL-21471-00	C-15	5DH-22212-60	E-12	4SS-23141-40	E-12	4DA-23389-00	D-8	5NY-25452-00	E-2	583-26352-00	E-10
5HD-21511-00	D-2	5DH-22212-70	E-12	4SS-23141-50	E-12	5HD-2339E-00	D-8	8CR-25715-00	E-6	5HD-26372-00	E-10
4XL-2153A-10	D-11	5ET-22212-00	E-12	4SS-23141-60	E-12	5HD-23393-L0	D-9	5DH-25718-01	E-4	5NY-26372-00	E-6
4ES-2153E-01	D-2	5ET-22212-10	D-6	4SS-23141-70	E-12		D-10	5MV-2580T-10	D-15	4XM-27200-00	E-7
3FY-21575-01	D-3		E-12	5BE-23141-L0	E-12	4EW-23416-00	D-8	5NY-2580W-00	E-4	5JG-27217-00	E-7
5BE-21611-10	D-2	5ET-22212-30	E-12	5BE-23141-00	E-12	5NL-23435-00	D-8	5MV-2581T-00	D-15	3SP-27222-00	E-8
5SG-2163G-00	D-2	5ET-22212-40	E-12	5CU-23141-L0	D-9	3SP-23441-00	D-8	4ML-2582A-50	E-8	5ET-27311-00	E-7
5BE-21642-00	D-2	5NG-22212-20	E-12		D-10	5HD-23485-10	D-8	5NY-2582W-00	E-4	5ET-27411-00	E-7
5BE-21711-00	D-3	5NG-22212-50	E-12	5ET-23141-00	E-12	5JG-24110-50	D-12	5DH-25827-50	E-4	5ET-27421-00	E-7
5NL-2172A-10	D-3	5NG-22212-60	E-12	5ET-23141-10	E-12	4EW-2412F-00	D-12	5DH-25828-50	E-4	4GY-27491-00	E-4
5BE-21721-00	D-3	5SF-22212-00	E-12	5ET-23141-20	E-12	24X-24144-00	D-12	5JG-2583V-00	E-8	5BE-2814F-00	C-15
5SF-2173E-01	D-3	3SP-22213-00	D-6	5ET-23141-30	E-12	5SF-24173-00	D-12	5MV-25833-00	E-6	5ET-28166-00	C-15
5SF-2173F-01	D-3	5DH-22214-00	D-6	5ET-23141-40	E-13	22W-24181-00	C-4	5BE-25844-01	E-8	5NL-28331-00	C-5
5NL-21731-00	D-3	5MV-22224-00	D-6	5GR-23141-00	E-12	4SS-24181-00	D-12	5BE-25852-00	E-8	4SR-82310-00	E-11
5SF-2174A-00	D-3	4JX-22226-00	D-6	5NL-23141-00	D-9	5BE-24182-00	D-12	5MV-25852-01	E-6	5BE-82370-00	E-11

NUMERICAL INDEX

PART NO.	GRID NO.	PART NO.	GRID NO.	PART NO.	GRID NO.	PART NO.	GRID NO.	PART NO.	GRID NO.	PART NO.	GRID NO.
5SG-82509-00	E-11	90119-08238	D-3	90201-10118	E-6	90387-225N2	E-5	90506-16500	E-7	93210-10197	B-10
5SF-82540-00	E-11	90122-06035	B-13		E-8	90401-08038	B-12	90508-142B5	C-9		C-5
5HD-82911-00	E-10	90149-06011	D-12	90201-10119	E-7	90401-10159	B-12	90508-162B2	B-7	93210-11073	E-7
5BE-82912-00	E-10	90149-06126	C-5	90201-12166	B-10	90401-10172	E-6	90508-26561	C-12	93210-12759	B-12
38V-82913-00	E-10	90149-06250	B-4	90201-14740	D-5		E-8	90508-282B8	E-7	93210-14369	C-6
5MV-83912-00	E-10	90149-06324	E-9	90201-15701	C-6	90430-06014	B-2	90508-282B9	E-7	93210-15414	B-9
5BE-83913-00	E-10	90149-06326	C-5	90201-160F6	D-4		B-7	90508-291A8	C-13	93210-15620	E-8
5MV-83922-00	E-6	90149-06327	D-15	90201-162H4	C-7		B-8	90508-30743	C-7	93210-16716	C-6
5HD-83951-00	E-10	90151-04048	D-4	90201-167P7	C-7	90430-08119	B-12	91A20-05065	B-9	93210-17570	C-7
5SF-83976-00	E-10	90152-06010	C-7	90201-177G4	C-7		C-14	91314-06030	B-10	93210-19123	C-15
583-83981-00	E-10	90154-05073	E-11	90201-203U1	E-3	90430-10188	B-12	91316-04008	B-14	93210-196A4	C-10
5SG-85540-00	E-11	90157-05095	E-8	90201-20685	C-7		C-5	91316-04012	B-14	93210-21276	E-11
5NL-85546-00	E-11	90157-08028	C-15	90201-247L2	D-8	90430-18130	C-14	91317-05008	D-4	93210-32172	C-6
5JG-85550-11	E-9	90159-06078	D-3	90201-286K9	D-8	90445-09104	D-12	91317-05014	B-13	93210-42263	D-9
5SF-85560-00	E-9	90159-06092	C-8	90202-05193	D-12	90445-09220	D-12	91317-06014	E-6		D-10
5JG-85885-00	C-2	90159-06182	D-3	90202-08045	B-14	90445-11002	D-12	91317-06016	E-11	93210-47675	B-12
9Y581-92111	E-3	90170-14171	B-4	90202-08204	C-15	90445-112K0	B-3	91317-06025	B-10	93300-60804	C-14
90101-06001	C-7	90170-16326	C-8	90206-06090	C-4	90450-22017	B-9	91317-06045	C-5	93306-00105	B-8
90101-06664	C-13	90170-24373	D-8	90209-06096	B-13		B-10	91317-06055	C-5	93306-00317	C-10
90101-08777	E-3	90179-06568	D-4	90209-20008	C-10	90450-25037	B-9	91317-06070	C-5	93306-00320	C-10
90105-06027	B-2	90179-08299	E-3	90209-23012	C-10	90450-32015	B-9	91317-08020	C-4	93306-07202	E-2
90105-06154	D-2	90179-10247	E-9	90215-14204	B-4	90450-54002	B-13	91401-20012	E-7	93306-20335	B-4
90105-065A1	C-6	90179-16672	D-14	90215-16289	C-8	90450-57092	B-13	91401-25015	E-7	93306-20447	C-10
90105-06553	C-5	90179-18001	C-8	90215-20003	C-8	90450-61001	B-13	91808-16023	B-7	93306-20648	B-4
	C-11		C-11		C-10	90464-13073	E-11	91812-16001	C-6	93306-27205	E-2
	E-8	90179-28650	D-8	90240-08120	E-7	90464-13077	E-11	92014-06016	E-8	93306-27208	C-10
90105-06690	D-2	90183-06023	B-13	90240-10142	E-7	90464-15152	E-11	92017-08055	C-14	93306-90403	D-14
90105-08099	C-14		D-2	90267-32070	B-13	90464-16061	E-11	92907-06100	D-13	93306-90501	C-12
90105-08659	D-15	90185-08169	C-14	90267-48121	C-4	90465-08029	C-6	92907-06600	B-7	93310-63003	B-4
90105-09002	B-2		E-3	90280-03001	B-4	90465-10013	C-5	92907-08200	D-15	93311-32261	B-4
90105-09555	B-2	90185-10002	C-14	90338-16148	C-14	90465-13275	E-11	93101-14164	C-6	93315-32053	D-5
90105-10323	D-6	90185-10060	D-7	90340-12112	B-2	90465-16258	E-6	93102-12106	B-8	93315-32056	D-4
90105-10733	C-14	90185-14007	D-5	90340-14128	C-6	90467-09006	B-9	93102-12224	B-7	93317-11287	C-8
90109-06027	E-10	90185-16127	D-4	90340-32123	C-6	90467-10008	D-12		C-8	93317-22262	D-4
90109-063F8	C-12	90185-20168	E-3	90387-06009	D-2	90467-11106	B-3		C-13	93332-00068	D-8
90109-06418	B-7	90201-03313	B-13	90387-0614M	B-9	90467-12085	E-8	93102-18278	C-7	93332-00081	D-8
90109-065G2	B-12	90201-06071	B-9	90387-0701A	D-2	90467-14015	B-3	93102-26468	D-14	93340-21008	C-8
90109-065G4	E-4	90201-06557	D-2	90387-0814J	C-4	90467-17089	B-13	93102-28008	C-10	93342-22217	D-4
90109-066F0	B-3	90201-080H1	C-8	90387-086N4	C-14	90468-16191	E-7	93106-22019	D-4	93410-20038	C-7
90109-081G1	E-3	90201-08089	E-7	90387-124F4	C-13	90480-08608	E-3	93106-30044	E-2	93410-22039	C-10
90109-082G0	C-7	90201-081R9	C-4	90387-16005	D-4	90480-15528	B-9	93106-30045	E-2	93410-26067	C-10
90110-08096	C-14	90201-08326	C-7	90387-16007	D-4	90480-18549	D-12	93109-11073	B-8	93420-16086	B-4
90116-06541	B-2		E-3	90387-167Y9	D-4	90501-043E0	B-12	93109-20076	D-4	93440-07149	B-2
90119-05071	D-8	90201-08410	C-2	90387-18004	D-4	90501-052G5	C-13		D-5	93440-07182	B-8
90119-06001	C-15	90201-08512	B-8	90387-18005	D-4	90501-06022	C-12	93109-28043	D-4		C-8
90119-06096	D-2	90201-086P8	C-14	90387-18007	C-5	90501-12081	C-7	93210-07003	B-12	93440-10153	B-2
90119-06214	D-12	90201-096J9	B-2	90387-20006	C-10	90501-16016	C-7	93210-07135	B-12		B-10
90119-06225	D-8	90201-101J1	E-9	90387-22001	C-10	90501-224J9	C-8	93210-09008	B-12	93440-41178	B-7

NUMERICAL INDEX

PART NO.	GRID NO.	PART NO.	GRID NO.	PART NO.	GRID NO.	PART NO.	GRID NO.	PART NO.	GRID NO.	PART NO.	GRID NO.
93503-08007	B - 12	95027-06025	B - 7	98707-06025	D - 12						
93507-32009	C - 7		B - 8	98907-05020	E - 10						
93511-32027	C - 8		B - 9	98907-06020	D - 12						
93603-16219	B - 10		B - 10	98980-06008	C - 4						
93604-10011	B - 8		B - 11	99001-08600	B - 10						
93608-33002	C - 13		B - 12	99009-12400	B - 10						
93612-16254	B - 3		C - 6	99009-16400	C - 7						
	C - 5	95027-06035	B - 3	99009-17400	C - 7						
9383B-13218	C - 10		C - 6	99009-22500	C - 6						
94108-21008	D - 14	95027-06050	D - 4	99009-45500	E - 2						
94108-2110Y	D - 14	95027-06065	B - 8	99244-00200	D - 5						
94108-2112Y	D - 14		B - 12	99530-08012	B - 10						
94110-1911A	E - 2	95027-08012	C - 15	99530-08016	C - 6						
94110-1913B	E - 2	95027-08020	D - 15	99530-10114	B - 10						
94110-1916A	E - 2	95027-08035	D - 8		C - 5						
94209-21229	D - 14	95027-08040	C - 14	99530-10116	C - 5						
94210-19222	E - 2		D - 8								
94210-19224	E - 2	95027-08065	C - 14								
94227-21101	D - 14	95027-10016	C - 5								
94309-21161	D - 14	95301-08700	E - 8								
94316-19156	E - 2	95607-05100	B - 13								
94321-19135	E - 2		E - 10								
94330-21084	D - 14	95607-06100	E - 10								
94416-21005	D - 14	95607-10200	D - 7								
94418-19003	E - 2	95617-08620	B - 2								
94591-53114	B - 7	95701-06500	E - 6								
94681-68001	E - 3	95704-06500	B - 3								
94701-00318	B - 2	95707-08500	B - 2								
94701-00319	B - 2		C - 14								
94701-00329	B - 2	95817-08016	C - 4								
94701-00330	B - 2		C - 15								
94703-00318	B - 2	95817-08030	C - 4								
94703-00319	B - 2	95817-10050	C - 14								
94703-00329	B - 2	95817-10130	C - 14								
94703-00330	B - 2	95827-06010	B - 9								
95024-06020	B - 10	95827-06012	D - 15								
95027-06010	C - 9	95827-06014	B - 7								
	D - 4	95827-06016	D - 3								
95027-06012	B - 2	95827-08012	C - 14								
	B - 8	97007-05016	E - 10								
	B - 9	97007-06012	D - 13								
	B - 12	97027-06016	B - 7								
	B - 13	97707-60016	D - 2								
	C - 15	97801-03008	D - 12								
	E - 4	98507-05020	E - 5								
95027-06016	D - 12	98507-06025	C - 5								
	E - 4	98706-04012	E - 6								
95027-06020	C - 13	98706-04040	E - 8								

CONTENTS

ENGINE

CYLINDER	B2
CRANKSHAFT. PISTON	B4
VALVE	B5
CAMSHAFT. CHAIN	B7
WATER PUMP	B8
RADIATOR. HOSE	B9
OIL PUMP	B10
OIL CLEANER	B12
INTAKE	B13
CARBURETOR	B14
EXHAUST	C4
CRANKCASE	C5
CRANKCASE COVER 1	C6
STARTER	C7
CLUTCH	C8
TRANSMISSION	C10
SHIFT CAM. FORK	C12
SHIFT SHAFT	C13

CHASSIS

FRAME	C14
FENDER	D2
SIDE COVER	D3
REAR ARM	D4
REAR SUSPENSION	D6
STEERING	D8
FRONT FORK	D9
FUEL TANK	D12
SEAT	D13
FRONT WHEEL	D14
FRONT BRAKE CALIPER	D15
REAR WHEEL	E2

REAR BRAKE CALIPER	E4
STEERING HANDLE. CABLE	E5
FRONT MASTER CYLINDER	E6
STAND. FOOTREST	E7
REAR MASTER CYLINDER	E8
GENERATOR	E9
HANDLE SWITCH. LEVER	E10
ELECTRICAL 1	E11
ALTERNATE (CHASSIS)	E12

INDEX

NUMERICAL INDEX	M1
-----------------------	----